



24 January 2024

Applecross Tennis Club Ltd
32 The Strand
Applecross WA 6153

Musco Lighting Australia, Pty Ltd
Unit 1, 28 Barcoo Street
Chatswood NSW Australia 2067

Phone: +61 2 9417 0100
Fax: +61 2 9417 7122
www.musco.com.au

Illumination Design Summary Report

The following report is to be read in conjunction with the Musco supplied document 230428_B.pdf lighting design, as an explanatory document to supplement the lighting design proposed for Applecross Tennis Club for Courts 11, 12, 13 and 14.

Design Brief:

The technical brief received was to light Courts 11 and 12, and Courts 13 and 14 to meet the AS 2560:2.1 requirements for competition tennis as per the below:

TABLE 1
LIGHTING CRITERIA

Level of play	Maintained horizontal illuminance* $E_{h \text{ maint}}$		Minimum horizontal uniformities [†]				Maximum Glare rating GR_{max}	Minimum Colour Rendering Index $R_{a \text{ min}}$
	PPA	TPA	PPA		TPA			
			$U_{1\text{min}}$	$U_{2\text{min}}$	$U_{1\text{min}}$	$U_{2\text{min}}$		
Recreational and residential ‡	250	150	0.6	0.3	0.2	0.1	50	20
Club competition and commercial	350	250	0.6	0.4	0.3	0.2	50	65
International and national	1000	800	0.7	0.5	0.5	0.3	50	65

Additionally, the design must comply with AS 4282:2023 Zone A3 Medium District Brightness requirements for the control of effects of obtrusive light (also known as spill light), and the requirement for no more than 0.2lx on the Swan River, the design brief in controlling spill light to ensure there is no light from the tennis courts reaching the river.

Descriptive Summary of Results

The descriptive summary will reference the Grid Summary label on each page of the design for reconciliation of the descriptive summary to the design document. The page references will reconcile with the PDF page numbering.

The values summarized below are in compliance with AS 2560 Table 1 above.

1 Tennis #13 PPA – Page 2 – Shows the results for the PPA columns on Table 1 above for Court 13. This shows an average light level of 356lx, Min/Avg (U1) of 0.74 and Min/Max (U2) of 0.58.

2 Tennis #13 TPA – Page 3 – Shows the results for the TPA columns on Table 1 above for Court 13. This shows an average light level of 304lx, Min/Avg (U1) of 0.34 and Min/Max (U2) of 0.23.

3 Glare Tennis #13 GR – Page 4 – Shows the results for the GR (Glare Rating) columns on Table 1 above for Court 13. This shows a maximum GR of 37.

4 Tennis #14 TPA – Page 5 – Shows the results for the PPA columns on Table 1 above for Court 14. This shows an average light level of 356lx, Min/Avg (U1) of 0.70 and Min/Max (U2) of 0.54.

5 Tennis #14 TPA – Page 6 – Shows the results for the TPA columns on Table 1 above for Court 14. This shows an average light level of 303lx, Min/Avg (U1) of 0.31 and Min/Max (U2) of 0.20.

6 Glare Tennis #14 GR – Page 7 – Shows the results for the GR (Glare Rating) columns on Table 1 above for Court 14. This shows a maximum GR of 37.

7 Tennis #12 PPA – Page 8 – Shows the results for the PPA columns on Table 1 above for Court 12. This shows an average light level of 371lx, Min/Avg (U1) of 0.62 and Min/Max (U2) of 0.41.

8 Tennis #12 TPA – Page 9 – Shows the results for the TPA columns on Table 1 above for Court 12. This shows an average light level of 330lx, Min/Avg (U1) of 0.41 and Min/Max (U2) of 0.24.

9 Glare Tennis #12 GR – Page 10 – Shows the results for the GR (Glare Rating) columns on Table 1 above for Court 12. This shows a maximum GR of 42.

10 Tennis #11 PPA – Page 11 – Shows the results for the PPA columns on Table 1 above for Court 11. This shows an average light level of 377lx, Min/Avg (U1) of 0.62 and Min/Max (U2) of 0.43.

11 Tennis #11 TPA – Page 12 – Shows the results for the TPA columns on Table 1 above for Court 11. This shows an average light level of 331lx, Min/Avg (U1) of 0.32 and Min/Max (U2) of 0.20.

12 Glare Tennis #11 GR – Page 13 – Shows the results for the GR (Glare Rating) columns on Table 1 above for Court 11. This shows a maximum GR of 42.

Obtrusive Light Descriptive Summary

AS 4282 specifies that the light level is to be assessed at 1.5m above ground level (grade), and that all calculation points are to be assessed on the basis that there are no blockages between the light source and the measurement point. (i.e. cannot allow for light blockage by trees or other structures) and must be assessed with a maintenance factor of 1.00 (i.e there is soiling or other light depreciation). In layman's terms, we are required to treat the light source at it's best performance, and there is nothing to mitigate or interfere with the light between the source and the calculation point.

13 Spill – Page 14 – this shows calculation points surrounding the proposed installation on a 5m x 5m grid. It can be seen there is no light contribution from the court lighting beyond the cycle path on the river side of the courts, and no light beyond the road.

Equipment Layout - Page 15 shows the pole locations in relation to the aiming point (indicated in the centre of Court 13). Pole heights and number of fixtures per pole are indicated on Page 15 on the table on the right of the page.

Applecross Tennis Club

Applecross,WA

Lighting System

Pole / Fixture Summary						
Pole ID	Pole Height	Mtg Height	Fixture Qty	Luminaire Type	Load	Circuit
P1-P4	8.0	8.0	1	TLC-LED-400	0.40 kW	A
P5-P8	8.0	8.0	1	TLC-LED-400	0.40 kW	B
P9-P12	10.0	10.0	2	TLC-LED-400	0.80 kW	C
12			16		6.40 kW	

Circuit Summary			
Circuit	Description	Load	Fixture Qty
A		1.6 kW	4
B		1.6 kW	4
C		3.2 kW	8

Fixture Type Summary							
Type	Source	Wattage	Lumens	L90	L80	L70	Quantity
TLC-LED-400	LED 5700K - 75 CRI	400W	46,500	>120,000	>120,000	>120,000	16

Single Luminaire Amperage Draw Chart							
Driver (.90 min power factor)	Line Amperage Per Luminaire						
Single Phase Voltage	220 (50)	230 (50)	240 (50)	380 (50)	400 (50)	415 (50)	
TLC-LED-400	2.2	2.1	2.0	1.3	1.2	1.2	

Light Level Summary

Calculation Grid Summary								
Grid Name	Calculation Metric	Illumination					Circuits	Fixture Qty
		Ave	Min	Max	Min/Max	Min/Ave		
01 Tennis #13 - PPA	Horizontal Illuminance	356	264	455	0.58	0.74	A	4
02 Tennis #13 - TPA	Horizontal Illuminance	304	103	455	0.23	0.34	A	4
03 Glare - Tennis #13	Glare Rating	33.9	28	37	0.75	0.83	A	4
04 Tennis #14 - PPA	Horizontal Illuminance	357	250	463	0.54	0.70	B	4
05 Tennis #14 - TPA	Horizontal Illuminance	303	93	463	0.20	0.31	B	4
06 Glare - Tennis #14	Glare Rating	33.6	28	37	0.75	0.83	B	4
07 Tennis #12 - PPA	Horizontal Illuminance	371	231	544	0.43	0.62	C	8
08 Tennis #12 - TPA	Horizontal Illuminance	331	135	556	0.24	0.41	C	8
09 Glare - Tennis #12	Glare Rating	35.1	10	42	0.24	0.28	C	8
10 Tennis #11 - PPA	Horizontal Illuminance	378	234	544	0.43	0.62	C	8
11 Tennis #11 - TPA	Horizontal Illuminance	331	106	544	0.20	0.32	C	8
12 Glare - Tennis #11	Glare Rating	35	10	42	0.24	0.29	C	8
13 Spill	True Max Vert Illuminance	41.1	0	574	0.00	0.00	A,B,C	16

From Hometown to Professional

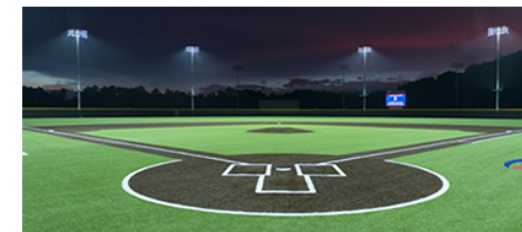

We Make It Happen.

Not to be reproduced in whole or part without the written consent of Musco Sports Lighting, LLC. ©1981, 2023 Musco Sports Lighting, LLC.

EQUIPMENT LIST FOR AREAS SHOWN

Pole			Luminaires					
QTY	LOCATION	SIZE	GRADE ELEVATION	MOUNTING HEIGHT	LUMINAIRE TYPE	QTY / POLE	THIS GRID	OTHER GRIDS
4	P1-P4	8m	-	8m	TLC-LED-400	1	1	0
4	TOTALS					4	4	0

Applecross Tennis Club
Applecross,WA

GRID SUMMARY	
Name:	01 Tennis #13 - PPA
Size:	35.8m x 19.0m
Spacing:	2.0m x 2.0m
Height:	1.0m above grade

ILLUMINATION SUMMARY	
MAINTAINED HORIZONTAL LUX	
Entire Grid	
Scan Average:	356.33
Maximum:	455
Minimum:	264
Min / Avg:	0.74
Min / Max:	0.58
UG (adjacent pts):	1.35
CU:	0.55
No. of Points:	65
LUMINAIRE INFORMATION	
Applied Circuits:	A
No. of Luminaires:	4
Total Load:	1.6 kW

Guaranteed Performance: The ILLUMINATION described above is guaranteed per your Musco Warranty document and includes a 0.95 dirt depreciation factor.

Field Measurements: Individual field measurements may vary from computer-calculated predictions and should be taken in accordance with IESNA RP-6-15.

Electrical System Requirements: Refer to Amperage Draw Chart and/or the "Musco Control System Summary" for electrical sizing.

Installation Requirements: Results assume 73% nominal voltage at line side of the driver and structures located within 3 feet (1m) of design locations.

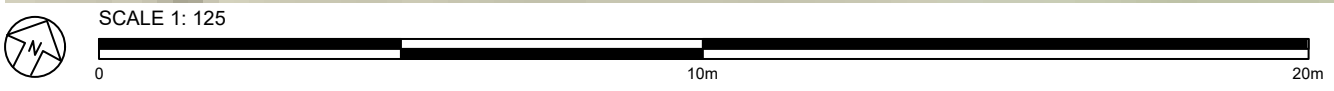
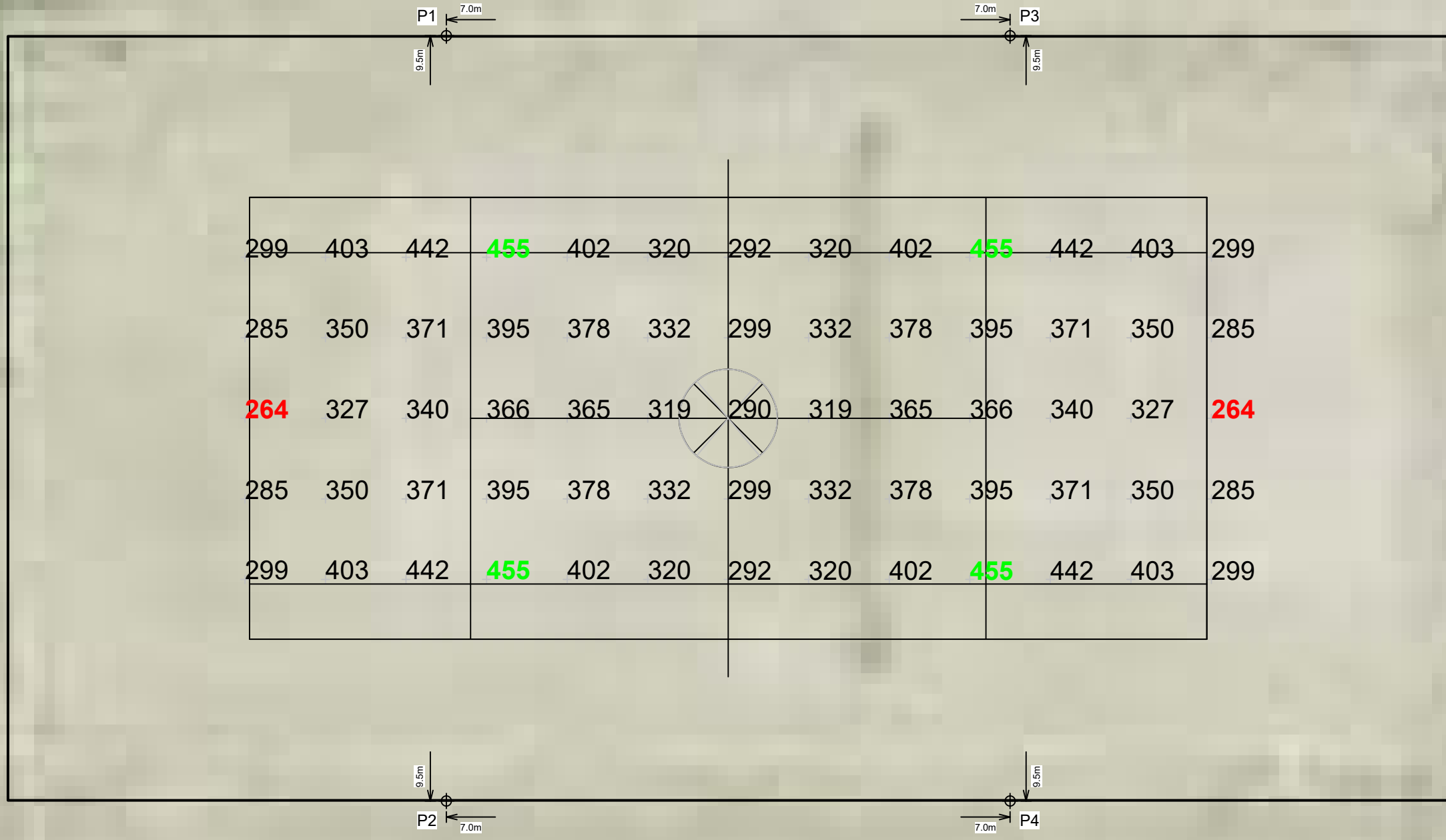

Pole location(s) ⊕ dimensions are relative to 0,0 reference point(s) ⊗



EQUIPMENT LIST FOR AREAS SHOWN

Pole				Luminaires				
QTY	LOCATION	SIZE	GRADE ELEVATION	MOUNTING HEIGHT	LUMINAIRE TYPE	QTY / POLE	THIS GRID	OTHER GRIDS
4	P1-P4	8m	-	8m	TLC-LED-400	1	1	0
4	TOTALS					4	4	0

Applecross Tennis Club
Applecross, WA

GRID SUMMARY	
Name:	02 Tennis #13 - TPA
Size:	35.8m x 19.0m
Spacing:	2.0m x 2.0m
Height:	1.0m above grade

ILLUMINATION SUMMARY	
MAINTAINED HORIZONTAL LUX	
	Entire Grid
Scan Average:	304.00
Maximum:	455
Minimum:	103
Min / Avg:	0.34
Min / Max:	0.23
UG (adjacent pts):	1.85
CU:	0.82
No. of Points:	115
LUMINAIRE INFORMATION	
Applied Circuits:	A
No. of Luminaires:	4
Total Load:	1.6 kW

Guaranteed Performance: The ILLUMINATION described above is guaranteed per your Musco Warranty document and includes a 0.95 dirt depreciation factor.

Field Measurements: Individual field measurements may vary from computer-calculated predictions and should be taken in accordance with IESNA RP-6-15.

Electrical System Requirements: Refer to Amperage Draw Chart and/or the "Musco Control System Summary" for electrical sizing.

Installation Requirements: Results assume 73% nominal voltage at line side of the driver and structures located within 3 feet (1m) of design locations.

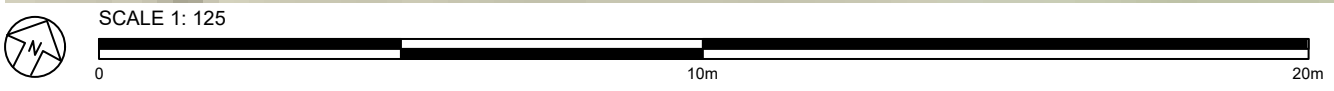
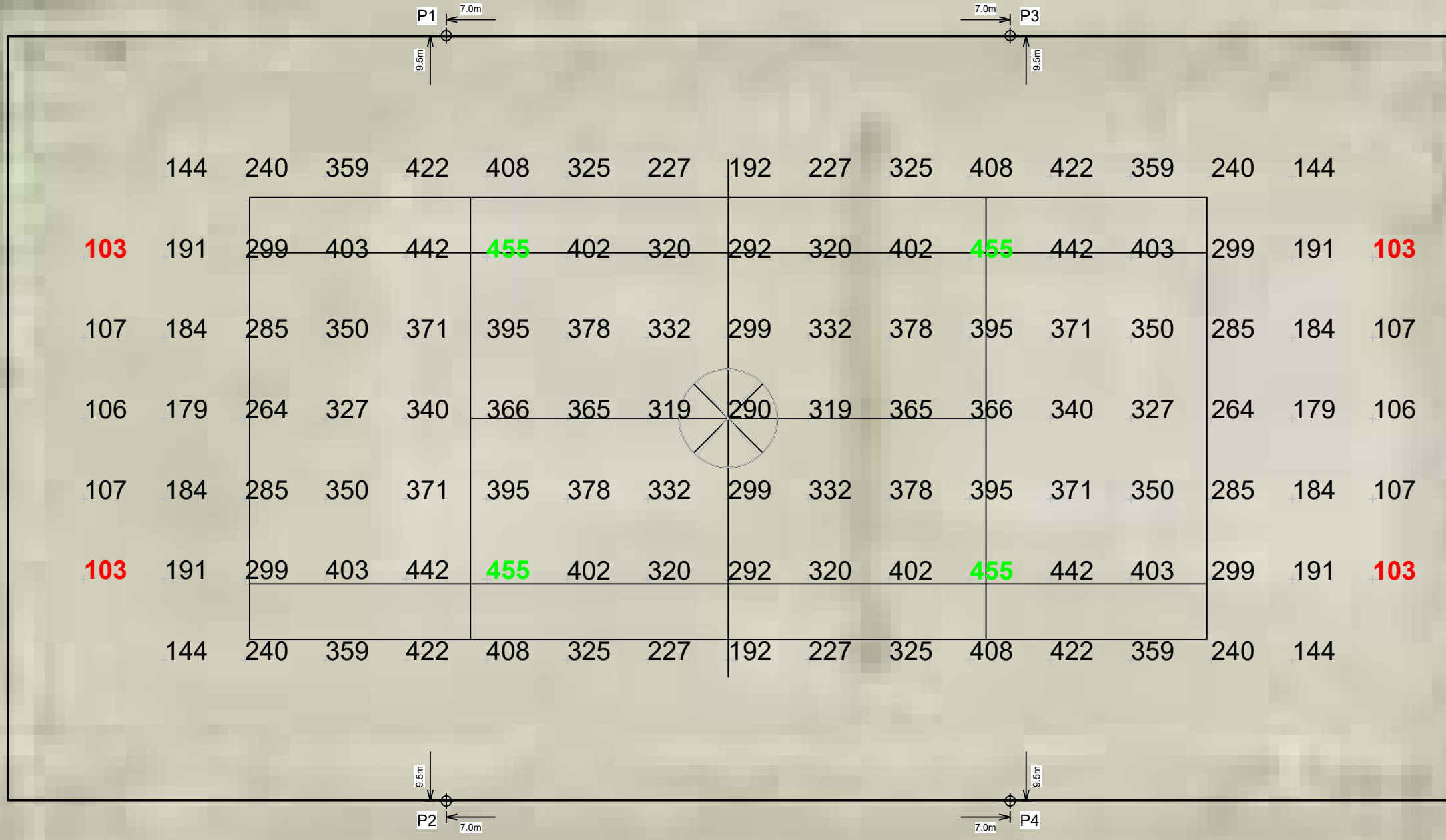

Pole location(s) ⊕ dimensions are relative to 0,0 reference point(s) ⊗



Not to be reproduced in whole or part without the written consent of Musco Sports Lighting, LLC. ©1981, 2023 Musco Sports Lighting, LLC.

ILLUMINATION SUMMARY

EQUIPMENT LIST FOR AREAS SHOWN

Pole			Luminaires					
QTY	LOCATION	SIZE	GRADE ELEVATION	MOUNTING HEIGHT	LUMINAIRE TYPE	QTY / POLE	THIS GRID	OTHER GRIDS
4	P5-P8	8m	-	8m	TLC-LED-400	1	1	0
4	TOTALS					4	4	0

Applecross Tennis Club
Applecross,WA

GRID SUMMARY	
Name:	04 Tennis #14 - PPA
Size:	35.8m x 19.0m
Spacing:	2.0m x 2.0m
Height:	1.0m above grade

ILLUMINATION SUMMARY	
MAINTAINED HORIZONTAL LUX	
	Entire Grid
Scan Average:	356.57
Maximum:	463
Minimum:	250
Min / Avg:	0.70
Min / Max:	0.54
UG (adjacent pts):	1.37
CU:	0.55
No. of Points:	65
LUMINAIRE INFORMATION	
Applied Circuits:	B
No. of Luminaires:	4
Total Load:	1.6 kW

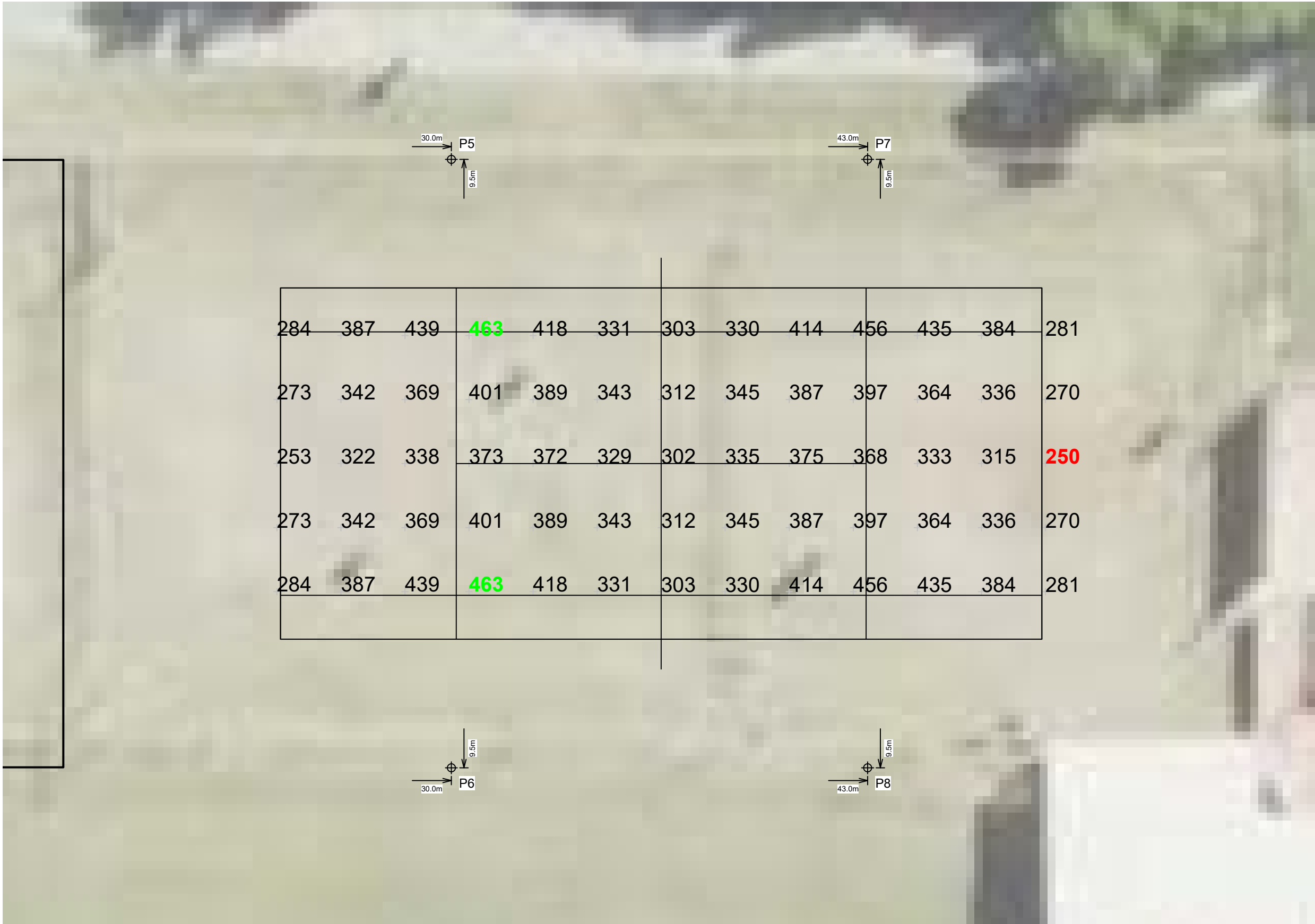

284	387	439	463	418	331	303	330	414	456	435	384	281
273	342	369	401	389	343	312	345	387	397	364	336	270
253	322	338	373	372	329	302	335	375	368	333	315	250
273	342	369	401	389	343	312	345	387	397	364	336	270
284	387	439	463	418	331	303	330	414	456	435	384	281

Guaranteed Performance: The ILLUMINATION described above is guaranteed per your Musco Warranty document and includes a 0.95 dirt depreciation factor.

Field Measurements: Individual field measurements may vary from computer-calculated predictions and should be taken in accordance with IESNA RP-6-15.

Electrical System Requirements: Refer to Amperage Draw Chart and/or the "Musco Control System Summary" for electrical sizing.

Installation Requirements: Results assume 73% nominal voltage at line side of the driver and structures located within 3 feet (1m) of design locations.

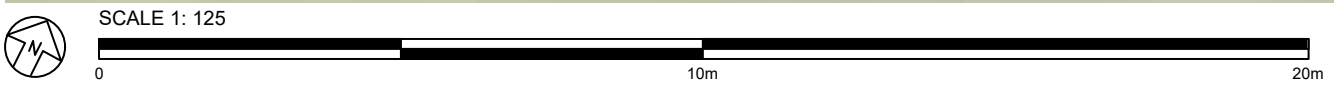

Pole location(s) ⊕ dimensions are relative to 0,0 reference point(s) ⊗



Not to be reproduced in whole or part without the written consent of Musco Sports Lighting, LLC. ©1981, 2023 Musco Sports Lighting, LLC.

EQUIPMENT LIST FOR AREAS SHOWN

Pole				Luminaires				
QTY	LOCATION	SIZE	GRADE ELEVATION	MOUNTING HEIGHT	LUMINAIRE TYPE	QTY / POLE	THIS GRID	OTHER GRIDS
4	P5-P8	8m	-	8m	TLC-LED-400	1	1	0
4	TOTALS					4	4	0

Applecross Tennis Club
Applecross, WA

GRID SUMMARY	
Name:	05 Tennis #14 - TPA
Size:	35.8m x 19.0m
Spacing:	2.0m x 2.0m
Height:	1.0m above grade

ILLUMINATION SUMMARY	
MAINTAINED HORIZONTAL LUX	
	Entire Grid
Scan Average:	303.19
Maximum:	463
Minimum:	93
Min / Avg:	0.31
Min / Max:	0.20
UG (adjacent pts):	1.87
CU:	0.82
No. of Points:	115
LUMINAIRE INFORMATION	
Applied Circuits:	B
No. of Luminaires:	4
Total Load:	1.6 kW



Guaranteed Performance: The ILLUMINATION described above is guaranteed per your Musco Warranty document and includes a 0.95 dirt depreciation factor.

Field Measurements: Individual field measurements may vary from computer-calculated predictions and should be taken in accordance with IESNA RP-6-15.

Electrical System Requirements: Refer to Amperage Draw Chart and/or the "Musco Control System Summary" for electrical sizing.

Installation Requirements: Results assume 73% nominal voltage at line side of the driver and structures located within 3 feet (1m) of design locations.

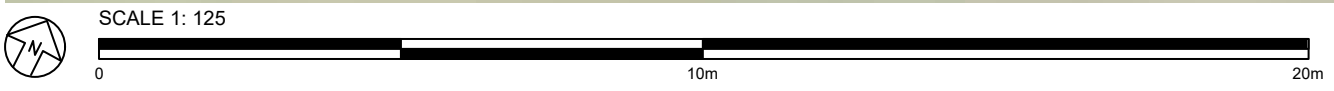

Pole location(s) ⊕ dimensions are relative to 0,0 reference point(s) ⊗



Not to be reproduced in whole or part without the written consent of Musco Sports Lighting, LLC. ©1981, 2023 Musco Sports Lighting, LLC.

ILLUMINATION SUMMARY

EQUIPMENT LIST FOR AREAS SHOWN

Pole			Luminaires					
QTY	LOCATION	SIZE	GRADE ELEVATION	MOUNTING HEIGHT	LUMINAIRE TYPE	QTY / POLE	THIS GRID	OTHER GRIDS
4	P5-P8	8m	-	8m	TLC-LED-400	1	1	0
4	TOTALS					4	4	0

Applecross Tennis Club
Applecross,WA

GRID SUMMARY	
Name:	06 Glare - Tennis #14
Size:	35.8m x 19.0m
Spacing:	2.0m x 2.0m
Height:	1.5m above grade

ILLUMINATION SUMMARY	
MAINTAINED GLARE RATING: Max Reading	
Entire Grid	
Scan Average:	33.57
Maximum:	37
Minimum:	28
No. of Points:	115
LUMINAIRE INFORMATION	
Applied Circuits:	B
No. of Luminaires:	4
Total Load:	1.6 kW

Guaranteed Performance: The ILLUMINATION described above is guaranteed per your Musco Warranty document and includes a 0.95 dirt depreciation factor.

Field Measurements: Individual field measurements may vary from computer-calculated predictions and should be taken in accordance with IESNA RP-6-15.

Electrical System Requirements: Refer to Amperage Draw Chart and/or the "Musco Control System Summary" for electrical sizing.

Installation Requirements: Results assume 73% nominal voltage at line side of the driver and structures located within 3 feet (1m) of design locations.

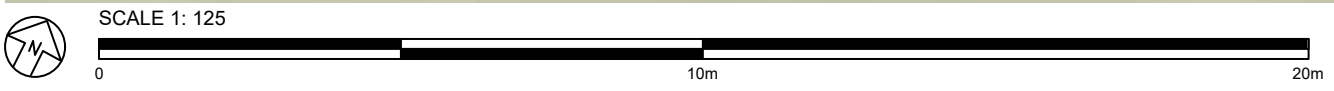
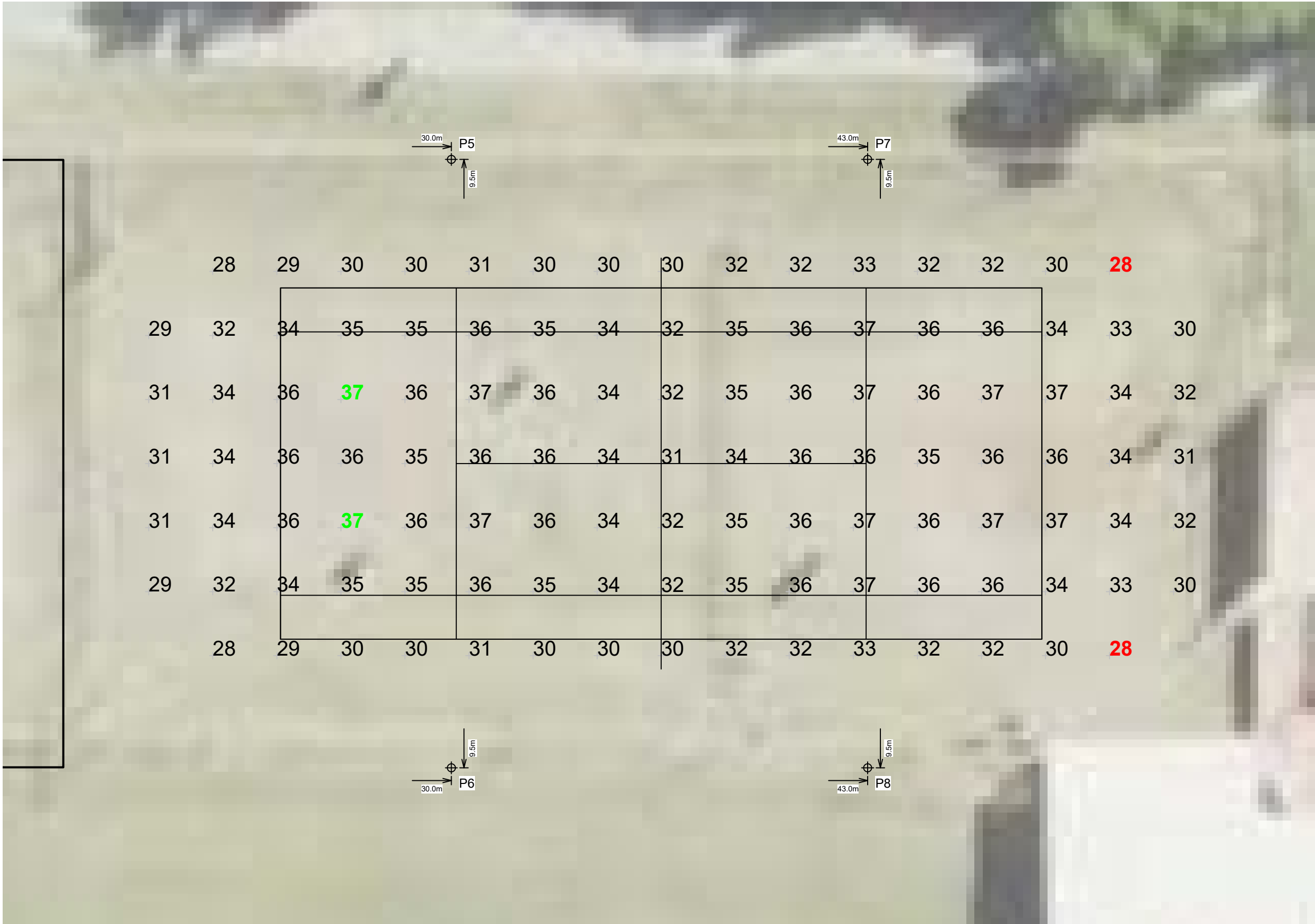

Pole location(s) ⊕ dimensions are relative to 0,0 reference point(s) ⊗



Not to be reproduced in whole or part without the written consent of Musco Sports Lighting, LLC. ©1981, 2023 Musco Sports Lighting, LLC.

ILLUMINATION SUMMARY

EQUIPMENT LIST FOR AREAS SHOWN

Pole			Luminaires					
QTY	LOCATION	SIZE	GRADE ELEVATION	MOUNTING HEIGHT	LUMINAIRE TYPE	QTY / POLE	THIS GRID	OTHER GRIDS
4	P9-P12	10m	-	10m	TLC-LED-400	2	2	0
4	TOTALS					8	8	0

Applecross Tennis Club
Applecross, WA

GRID SUMMARY	
Name:	07 Tennis #12 - PPA
Size:	35.8m x 19.0m
Spacing:	2.0m x 2.0m
Height:	1.0m above grade

ILLUMINATION SUMMARY	
MAINTAINED HORIZONTAL LUX	
Entire Grid	
Scan Average:	371.11
Maximum:	544
Minimum:	231
Min / Avg:	0.62
Min / Max:	0.43
UG (adjacent pts):	1.43
CU:	0.25
No. of Points:	65
LUMINAIRE INFORMATION	
Applied Circuits:	C
No. of Luminaires:	8
Total Load:	3.2 kW

Guaranteed Performance: The ILLUMINATION described above is guaranteed per your Musco Warranty document and includes a 0.95 dirt depreciation factor.

Field Measurements: Individual field measurements may vary from computer-calculated predictions and should be taken in accordance with IESNA RP-6-15.

Electrical System Requirements: Refer to Amperage Draw Chart and/or the "Musco Control System Summary" for electrical sizing.

Installation Requirements: Results assume 73% nominal voltage at line side of the driver and structures located within 3 feet (1m) of design locations.

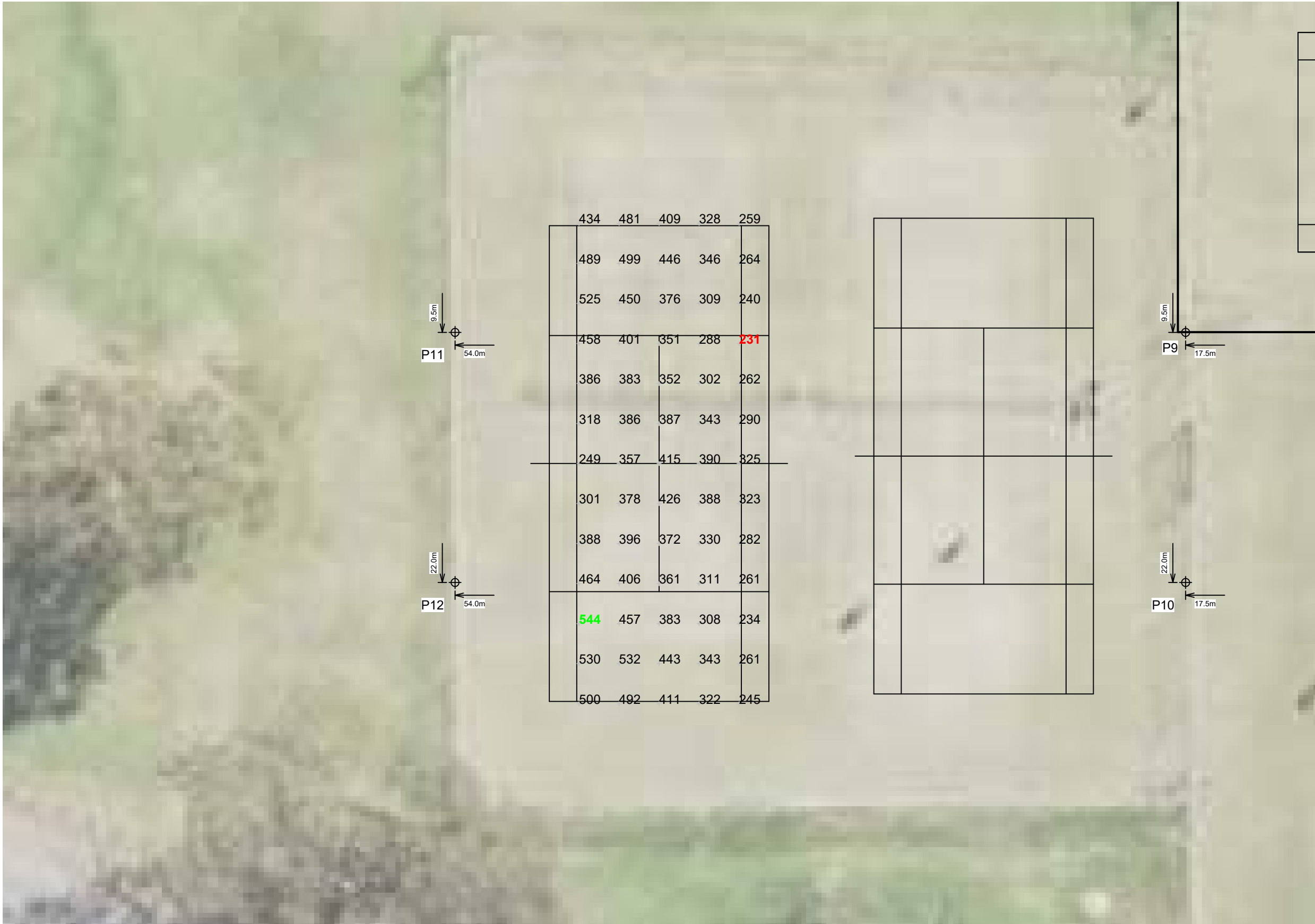

Pole location(s) ⊕ dimensions are relative to 0,0 reference point(s) ⊗



Not to be reproduced in whole or part without the written consent of Musco Sports Lighting, LLC. ©1981, 2023 Musco Sports Lighting, LLC.

ILLUMINATION SUMMARY

EQUIPMENT LIST FOR AREAS SHOWN

Pole				Luminaires				
QTY	LOCATION	SIZE	GRADE ELEVATION	MOUNTING HEIGHT	LUMINAIRE TYPE	QTY / POLE	THIS GRID	OTHER GRIDS
4	P9-P12	10m	-	10m	TLC-LED-400	2	2	0
4	TOTALS					8	8	0

Applecross Tennis Club
Applecross, WA

GRID SUMMARY	
Name:	08 Tennis #12 - TPA
Size:	35.8m x 19.0m
Spacing:	2.0m x 2.0m
Height:	1.0m above grade

ILLUMINATION SUMMARY	
MAINTAINED HORIZONTAL LUX	
Entire Grid	
Scan Average:	330.76
Maximum:	556
Minimum:	135
Min / Avg:	0.41
Min / Max:	0.24
UG (adjacent pts):	2.25
CU:	0.40
No. of Points:	115
LUMINAIRE INFORMATION	
Applied Circuits:	C
No. of Luminaires:	8
Total Load:	3.2 kW



Guaranteed Performance: The ILLUMINATION described above is guaranteed per your Musco Warranty document and includes a 0.95 dirt depreciation factor.

Field Measurements: Individual field measurements may vary from computer-calculated predictions and should be taken in accordance with IESNA RP-6-15.

Electrical System Requirements: Refer to Amperage Draw Chart and/or the "Musco Control System Summary" for electrical sizing.

Installation Requirements: Results assume 73% nominal voltage at line side of the driver and structures located within 3 feet (1m) of design locations.

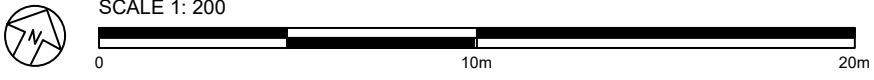

Pole location(s) ⊕ dimensions are relative to 0,0 reference point(s) ⊗



Not to be reproduced in whole or part without the written consent of Musco Sports Lighting, LLC. ©1981, 2023 Musco Sports Lighting, LLC.

ILLUMINATION SUMMARY

EQUIPMENT LIST FOR AREAS SHOWN

Pole				Luminaires				
QTY	LOCATION	SIZE	GRADE ELEVATION	MOUNTING HEIGHT	LUMINAIRE TYPE	QTY / POLE	THIS GRID	OTHER GRIDS
4	P9-P12	10m	-	10m	TLC-LED-400	2	2	0
4	TOTALS					8	8	0

Applecross Tennis Club
Applecross,WA

GRID SUMMARY	
Name:	09 Glare - Tennis #12
Size:	35.8m x 19.0m
Spacing:	2.0m x 2.0m
Height:	1.5m above grade

ILLUMINATION SUMMARY	
MAINTAINED GLARE RATING: Max Reading	
Entire Grid	
Scan Average:	35.10
Maximum:	42
Minimum:	10
No. of Points:	115
LUMINAIRE INFORMATION	
Applied Circuits:	C
No. of Luminaires:	8
Total Load:	3.2 kW

Guaranteed Performance: The ILLUMINATION described above is guaranteed per your Musco Warranty document and includes a 0.95 dirt depreciation factor.

Field Measurements: Individual field measurements may vary from computer-calculated predictions and should be taken in accordance with IESNA RP-6-15.

Electrical System Requirements: Refer to Amperage Draw Chart and/or the "Musco Control System Summary" for electrical sizing.

Installation Requirements: Results assume 73% nominal voltage at line side of the driver and structures located within 3 feet (1m) of design locations.



Pole location(s) ⊕ dimensions are relative to 0,0 reference point(s) ⊗



Not to be reproduced in whole or part without the written consent of Musco Sports Lighting, LLC. ©1981, 2023 Musco Sports Lighting, LLC.

ILLUMINATION SUMMARY

EQUIPMENT LIST FOR AREAS SHOWN

Pole				Luminaires				
QTY	LOCATION	SIZE	GRADE ELEVATION	MOUNTING HEIGHT	LUMINAIRE TYPE	QTY / POLE	THIS GRID	OTHER GRIDS
4	P9-P12	10m	-	10m	TLC-LED-400	2	2	0
4	TOTALS					8	8	0

Applecross Tennis Club
Applecross,WA

GRID SUMMARY	
Name:	10 Tennis #11 - PPA
Size:	35.8m x 19.0m
Spacing:	2.0m x 2.0m
Height:	1.0m above grade

ILLUMINATION SUMMARY	
MAINTAINED HORIZONTAL LUX	
Entire Grid	
Scan Average:	377.98
Maximum:	544
Minimum:	234
Min / Avg:	0.62
Min / Max:	0.43
UG (adjacent pts):	1.42
CU:	0.26
No. of Points:	65
LUMINAIRE INFORMATION	
Applied Circuits:	C
No. of Luminaires:	8
Total Load:	3.2 kW



Guaranteed Performance: The ILLUMINATION described above is guaranteed per your Musco Warranty document and includes a 0.95 dirt depreciation factor.

Field Measurements: Individual field measurements may vary from computer-calculated predictions and should be taken in accordance with IESNA RP-6-15.

Electrical System Requirements: Refer to Amperage Draw Chart and/or the "Musco Control System Summary" for electrical sizing.

Installation Requirements: Results assume 73% nominal voltage at line side of the driver and structures located within 3 feet (1m) of design locations.

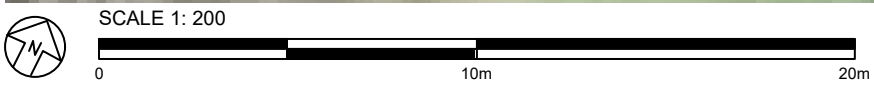

Pole location(s) ⊕ dimensions are relative to 0,0 reference point(s) ⊗



Not to be reproduced in whole or part without the written consent of Musco Sports Lighting, LLC. ©1981, 2023 Musco Sports Lighting, LLC.

ILLUMINATION SUMMARY

EQUIPMENT LIST FOR AREAS SHOWN

Pole		Luminaires						
QTY	LOCATION	SIZE	GRADE ELEVATION	MOUNTING HEIGHT	LUMINAIRE TYPE	QTY / POLE	THIS GRID	OTHER GRIDS
4	P9-P12	10m	-	10m	TLC-LED-400	2	2	0
4	TOTALS					8	8	0

Applecross Tennis Club
Applecross,WA

GRID SUMMARY	
Name:	11 Tennis #11 - TPA
Size:	35.8m x 19.0m
Spacing:	2.0m x 2.0m
Height:	1.0m above grade

ILLUMINATION SUMMARY	
MAINTAINED HORIZONTAL LUX	
Entire Grid	
Scan Average:	331.21
Maximum:	544
Minimum:	106
Min / Avg:	0.32
Min / Max:	0.20
UG (adjacent pts):	2.52
CU:	0.40
No. of Points:	115
LUMINAIRE INFORMATION	
Applied Circuits:	C
No. of Luminaires:	8
Total Load:	3.2 kW

Guaranteed Performance: The ILLUMINATION described above is guaranteed per your Musco Warranty document and includes a 0.95 dirt depreciation factor.

Field Measurements: Individual field measurements may vary from computer-calculated predictions and should be taken in accordance with IESNA RP-6-15.

Electrical System Requirements: Refer to Amperage Draw Chart and/or the "Musco Control System Summary" for electrical sizing.

Installation Requirements: Results assume 230V nominal voltage at line side of the driver and structures located within 3 feet (1m) of design locations.



177	217	248	224	114		
180	223	270	337	378	261	106
209	256	323	404	474	422	268
221	270	356	459	516	487	426
204	255	328	399	474	537	514
194	234	293	355	409	485	469
232	270	312	359	386	392	376
254	295	353	398	393	331	255
279	336	405	437	374	263	149
276	330	400	441	394	302	216
251	290	340	383	405	392	361
228	269	322	375	420	466	456
204	252	329	397	465	544	531
218	276	359	448	502	496	446
210	259	338	414	483	439	314
184	226	275	341	399	317	154
189	224	272	275	168		



Pole location(s) ⊕ dimensions are relative to 0,0 reference point(s) ⊗



EQUIPMENT LIST FOR AREAS SHOWN

Pole				Luminaires				
QTY	LOCATION	SIZE	GRADE ELEVATION	MOUNTING HEIGHT	LUMINAIRE TYPE	QTY / POLE	THIS GRID	OTHER GRIDS
4	P9-P12	10m	-	10m	TLC-LED-400	2	2	0
4	TOTALS					8	8	0

Applecross Tennis Club
Applecross,WA

GRID SUMMARY	
Name:	12 Glare - Tennis #11
Size:	35.8m x 19.0m
Spacing:	2.0m x 2.0m
Height:	1.5m above grade

ILLUMINATION SUMMARY	
MAINTAINED GLARE RATING: Max Reading	
Entire Grid	
Scan Average:	34.95
Maximum:	42
Minimum:	10
No. of Points:	115
LUMINAIRE INFORMATION	
Applied Circuits:	C
No. of Luminaires:	8
Total Load:	3.2 kW

Guaranteed Performance: The ILLUMINATION described above is guaranteed per your Musco Warranty document and includes a 0.95 dirt depreciation factor.

Field Measurements: Individual field measurements may vary from computer-calculated predictions and should be taken in accordance with IESNA RP-6-15.

Electrical System Requirements: Refer to Amperage Draw Chart and/or the "Musco Control System Summary" for electrical sizing.

Installation Requirements: Results assume 73% nominal voltage at line side of the driver and structures located within 3 feet (1m) of design locations.

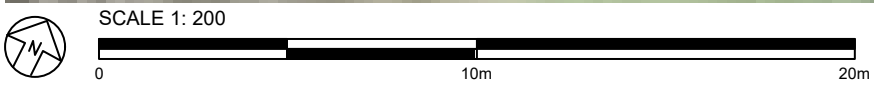

Pole location(s) ⊕ dimensions are relative to 0,0 reference point(s) ⊗



EQUIPMENT LIST FOR AREAS SHOWN

Pole			Luminaires					
QTY	LOCATION	SIZE	GRADE ELEVATION	MOUNTING HEIGHT	LUMINAIRE TYPE	QTY / POLE	THIS GRID	OTHER GRIDS
8	P1-P8	8m	-	8m	TLC-LED-400	1	1	0
4	P9-P12	10m	-	10m	TLC-LED-400	2	2	0
12	TOTALS					16	16	0

Applecross Tennis Club
Applecross, WA

GRID SUMMARY	
Name:	13 Spill
Size:	35.8m x 19.0m
Spacing:	5.0m x 5.0m
Height:	1.5m above grade

ILLUMINATION SUMMARY	
MAINTAINED MAX VERTICAL LUX	
Entire Grid	
Scan Average:	41.13
Maximum:	574
Minimum:	0
Min / Avg:	0.00
Min / Max:	0.00
UG (adjacent pts):	1707.46
CU:	1.00
No. of Points:	660
LUMINAIRE INFORMATION	
Applied Circuits:	A, B, C
No. of Luminaires:	16
Total Load:	6.4 kW



Guaranteed Performance: The ILLUMINATION described above is guaranteed per your Musco Warranty document and includes a 0.95 dirt depreciation factor.

Field Measurements: Individual field measurements may vary from computer-calculated predictions and should be taken in accordance with IESNA RP-6-15.

Electrical System Requirements: Refer to Amperage Draw Chart and/or the "Musco Control System Summary" for electrical sizing.

Installation Requirements: Results assume 73% nominal voltage at line side of the driver and structures located within 3 feet (1m) of design locations.



Pole location(s) ⊕ dimensions are relative to 0,0 reference point(s) ⊗



Not to be reproduced in whole or part without the written consent of Musco Sports Lighting, LLC. ©1981, 2023 Musco Sports Lighting, LLC.

ILLUMINATION SUMMARY

Applecross Tennis Club

Applecross, WA

EQUIPMENT LAYOUT

INCLUDES:
· Tennis

Electrical System Requirements: Refer to Amperage Draw Chart and/or the "Musco Control System Summary" for electrical sizing.

Installation Requirements: Results assume 73% nominal voltage at line side of the driver and structures located within 3 feet (1m) of design locations.

EQUIPMENT LIST FOR AREAS SHOWN

QTY	Pole			Luminaires		QTY/POLE
	LOCATION	SIZE	GRADE ELEVATION	MOUNTING HEIGHT	LUMINAIRE TYPE	
8	P1-P8	8m	-	8m	TLC-LED-400	1
4	P9-P12	10m	-	10m	TLC-LED-400	2
12	TOTALS					16

SINGLE LUMINAIRE AMPERAGE DRAW CHART

Driver (.90 min power factor)	Line Amperage Per Luminaire (max draw)					
	220 (50)	230 (50)	240 (50)	380 (50)	400 (50)	415 (50)
Single Phase Voltage	2.2	2.1	2.0	1.3	1.2	1.2
TLC-LED-400	2.2	2.1	2.0	1.3	1.2	1.2

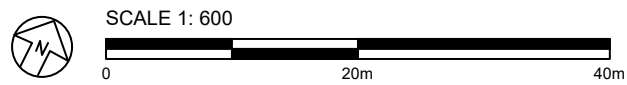
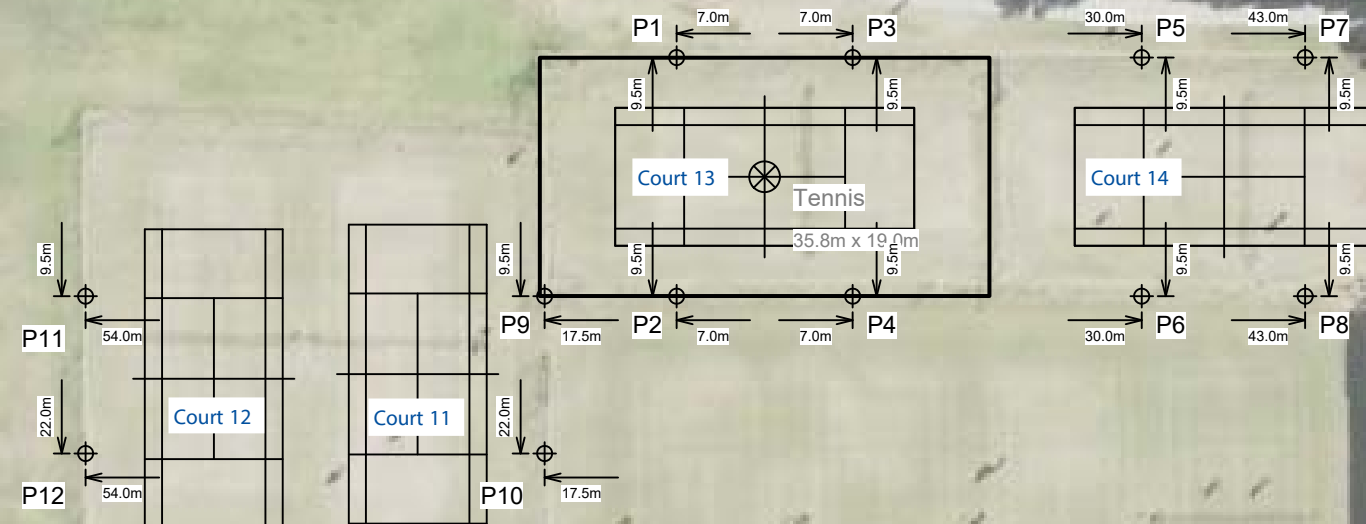

Pole location(s) ⊕ dimensions are relative to 0,0 reference point(s) ⊗



TLC *for* LED™

Total Light Control™



We Make It Happen®

Keeping Good Lighting Affordable

With the emergence of LED sports lighting, facility owners are discovering that different manufacturers produce vastly different results.

The LED light source has distinctive challenges and advantages. To realise the full potential of LED lighting, it takes experience and a proven system for controlling and applying the unique characteristics of the diode in a sports setting.

With Musco's more than 45 years of experience—and over a decade of researching LED—our Team has looked at the combination of issues to achieve the best solution to meet your needs from structures, to quality of on-pitch light, to off-site impact, to energy and costs.

The result is a system that makes Musco's great lighting even better.

Better for players...

who want to perform their best and be able to track the entire flight of the ball.

Better for fans...

who want to see the game better and enjoy world-class light shows watching preps or the pros.

Better for neighbours...

who won't have light spill or glare in their homes or lights left on when not in use.

Better for the night sky...

with more light directed onto the pitch and less spilling above it.

Better for your budget...

an affordable system that's built to last and control operating costs.

And you won't have to worry about maintenance costs for up to 10 years.

Control

from foundation to poletop...

from the light source to the pitch,
preserving the night sky...

assuring the results you expect,
day 1... year 1... and for 10 years.



A Unique System Design

5 Easy Pieces™ complete from foundation to poletop.

While other manufacturers produce single luminaires, our system approach delivers better long-term reliability and trouble-free operation.

Whether it's Light-Structure System™ complete from foundation to poletop, or SportsCluster™ system retrofitted to existing structures, we include lighting, structural, and electrical components designed to work together.

Our system provides a more protective environment for the LED's sensitive electronics, integrated grounding, surge protection, and remote drivers so servicing can be done from a step ladder, not a lift.

And we guarantee its performance for up to 10 years.



Control
from the foundation to the poletop.

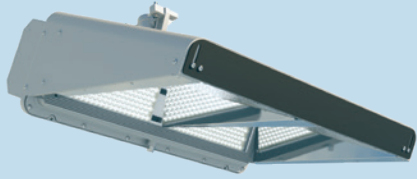

TLC for LED™
Total Light Control™

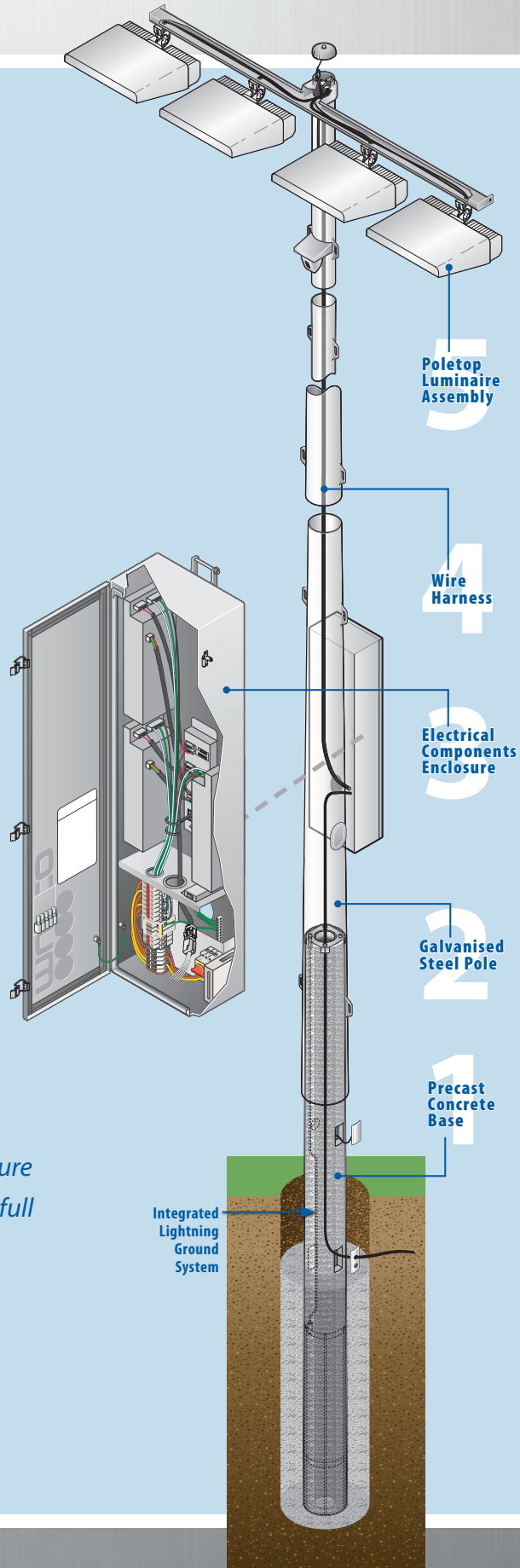

“Advancements in all aspects of fixture design are critical to achieving the full performance of LED technology.”

— U.S. Department of Energy
www.energy.gov/eere/ssl/led-basics

A Better Night Game Experience

The key issues in sports lighting haven't changed—how do you put more light onto the pitch, spill less around it, protect the night sky, reduce glare, and ensure it performs when needed and withstands the elements.

Our TLC for LED™ system delivers highly-controlled downward light from the poletop, along with precisely-targeted upward light from our BallTracker™ luminaires. Together, this patented system illuminates the underside of a ball in flight, creates better contrast against the dark night sky, and creates unparalleled cut-off, preventing spill and glare from affecting the surrounding area.

And for an enhanced entertainment experience, Musco's strategically located colour-changing luminaires and innovative light-to-sound synchronisation capabilities create big league light shows for players and fans at pitches of all sizes.

This is why, when you walk onto a pitch lighted by Musco, it just looks better.

"Now you can actually see the seams of the baseball coming in at you, and you can pick up spin easier. BallTracker is really important because when the ball gets up into the air it keeps the ball white against the dark sky. So it helps a lot."

— Nate Esposito, Wilmington Blue Rocks (MiLB)

Control from the light source to the pitch.

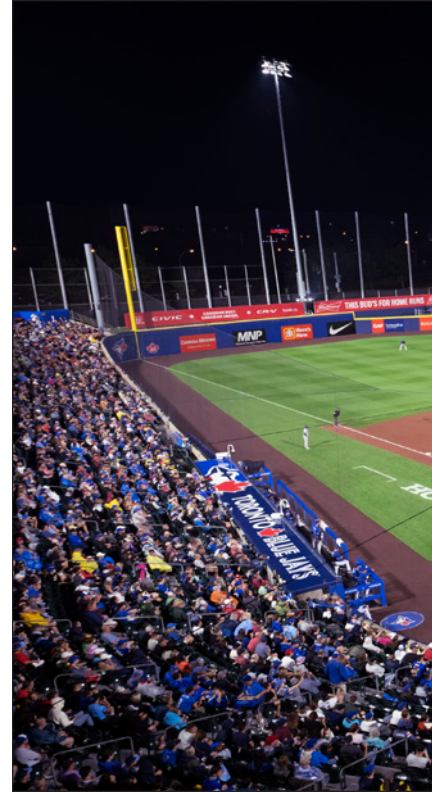

Sahlen Field - Buffalo, New York, USA

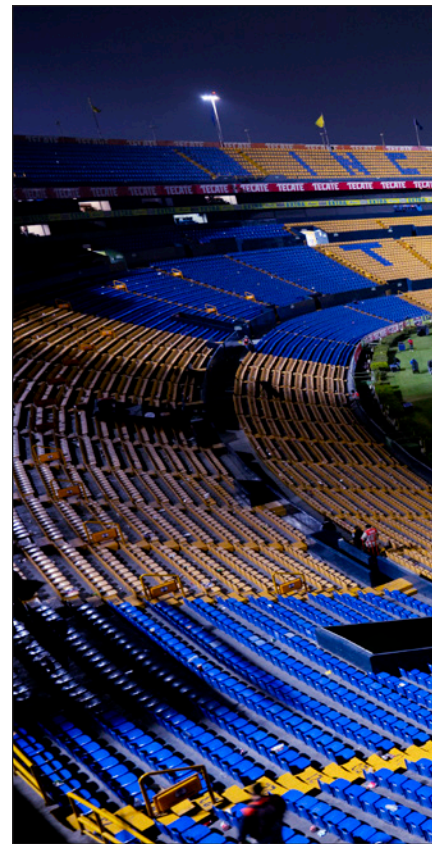

Estadio Tigres - Nuevo Leon, Mexico



With patented BallTracker™ technology, players enjoy quality lighting, no glare, and better ability to track the entire flight of the ball.



Mount Rushmore - Keystone, South Dakota, USA

Pinpoint control from 335 metres away highlights the target area while preserving surrounding darkness.



University of Notre Dame - Notre Dame, Indiana, USA

Event lighting with dimming saves energy for high-usage, multi-use venues.



Show-Light™ theatrics and special effects enhance fan and TV experience.

A Solution Neighbours Will Love

Emitting light is easy, controlling it isn't. At Musco, we care as much about preserving darkness around your pitch as we do putting high-quality lighting onto it.

Our system's custom optics, designed around the LEDs, control and apply the light precisely where it's needed. And our patented luminaire visoring greatly reduces glare at the light source.

This means no spill light or disruptive glare affecting neighbouring homes, and the preservation of dark skies above. It's why our system could be installed at a large, multi-pitch sports complex located in close proximity to an international airport.

Our light control capabilities have made lighting possible at pitches where, previously, it wasn't allowed due to community concerns.

Control
preserving the night sky.

"Glyndon Park is in a naturally wooded residential area. We didn't want to illuminate the homes of neighbours in the area. I initially wasn't supportive of putting in traditional lights. The product Musco has developed allows us to light this field, yet light nothing else around it."

— Parks and Recreation Director, Vienna, VA



Glyndon Park Little League, Vienna, Virginia, USA

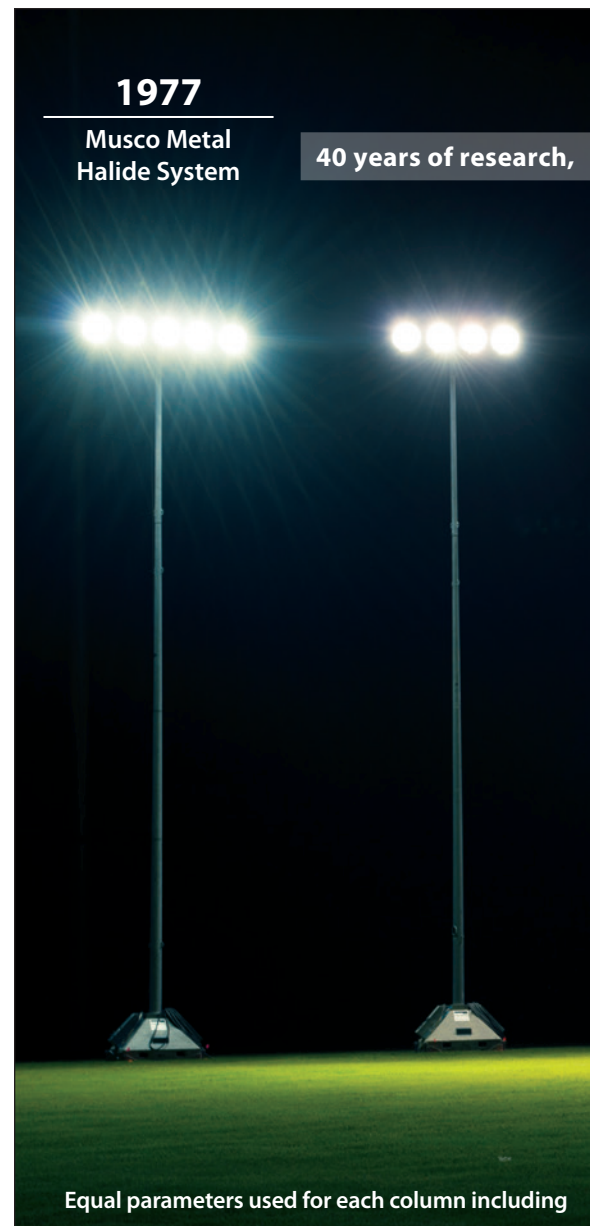

increasing efficiency and minimising environmental impact.

Today

Musco LED System

Today

Other Luminaire Manufacturer LED



on-pitch light produced, wattage, height, and aiming angle.

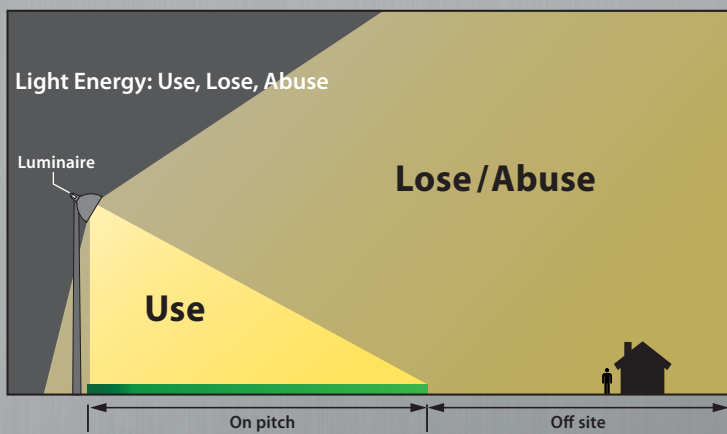

A Pitch That's Always Ready for Play

With the remote facility management of Musco's Control-Link™ service, your pitch will always have light when it's needed.

You'll be able to instantly turn your lights on or off from anywhere, with the touch of a smart phone. Our Team at Control-Link Central™ will be there for you 24/7 to provide scheduling and monitoring support.

In fact, if a problem arises we'll likely know about it before you do, right down to the luminaire. Here's a look at the service we provided customers in just the past year:

- *Turned lights on/off remotely for more than 7.6 million events.*
- *Conducted routine inspections and maintenance at over 11,000 pitches.*
- *Helped with scheduling and answered questions on over 297,000 calls, over 981,000 app sessions, and 1.3 million website logins.*
- *Traveled enough distance servicing pitches to circle the equator 24 times.*

And with our 10-year parts and labour warranty, you'll have peace of mind for the next 3650 days knowing that you'll pay zero maintenance costs, won't have headaches over staffing and managing your floodlights, and will be free from neighbours complaining about floodlights being left on.

Control assuring the results you expect.

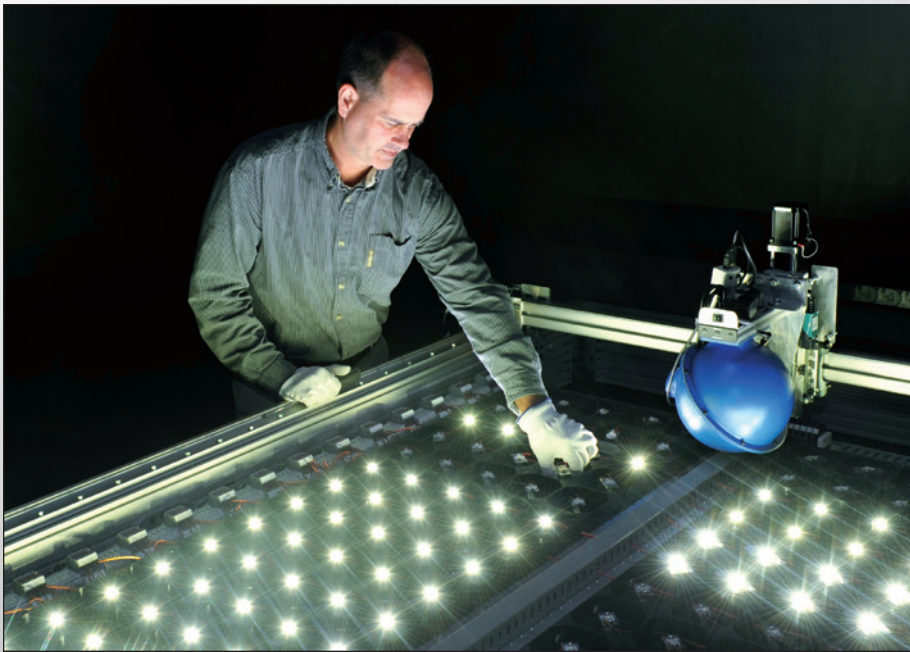

Our R&D, customisation, and application capabilities deliver solutions specific to each customer's needs.

"Musco called to let us know there was an issue before we knew we had a problem."

— Stephen Cooke, CPRP, CYSA
Greenville County Recreation Athletics Manager, Taylors, SC



Our regionally-based technicians provide prompt service for 10 years.



Our Control-Link™ service provides 24/7 proactive monitoring and the support of a fully staffed call center.



Musco's Light-Structure System™ performs in real world conditions **for 10 years, guaranteed.**

We Make It Happen.®

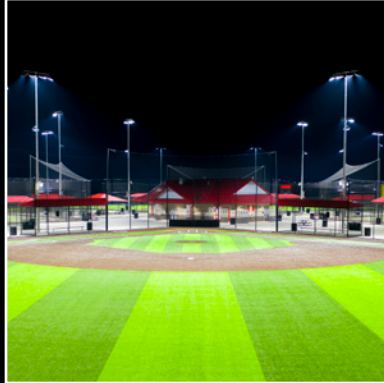

Control

from foundation to poletop...

from the light source to the pitch,
preserving the night sky...

assuring the results you expect,
day 1...year 1... and for 10 years.



We Make It Happen.

www.musco.com

e-mail: lighting@musco.com

Phone: 800.825.6030

Not all LED is created **equal**

Due to the intensity of the LED light source, increased measures should be taken to provide optic controls to minimize glare



Musco: what can be



2014 Musco Light-Structure Green System™ with LED light source
LakePoint Sporting Community · Emerson, Georgia, USA

What often is



2014 Other manufacturer's fixture with LED light source

For more than 40 years the Musco Team has focused on researching control of light energy to deliver affordable systems that minimize glare and spill . . . reduce energy . . . provide optimal environment for athletes, spectators, and HD broadcasts . . . and assure long term trouble-free operation.

Luminaire and Driver – TLC-LED-400

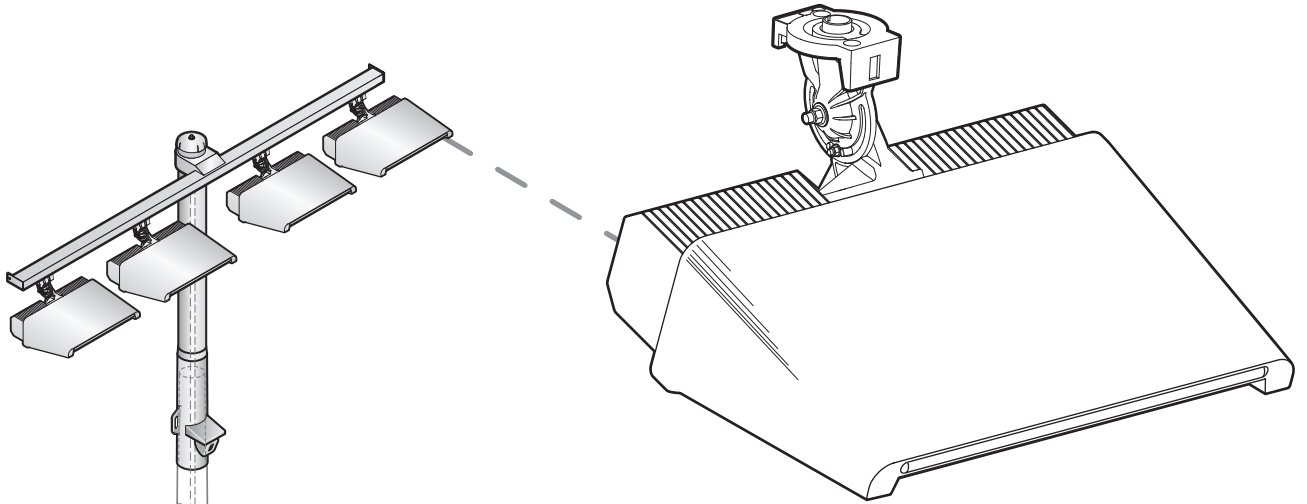

Luminaire Data

Weight (luminaire)	40 lb (18 kg)
UL listing number	E338094
UL listed for USA/Canada	UL1598 CSA-C22.2 No.250.0
CE Declaration	LVD, EMC, RoHS
Ingress protection (luminaire)	IP65
Impact rating	IK07
Material and finish	Aluminum, powder-coat painted
Wind speed rating (aiming only)	150 mi/h (67 m/s)
UL, IEC ambient temperature rating (luminaire)	50°C (122°F)

Photometric Characteristics

Projected lumen maintenance per IES TM-21-11	
L90 (20k)	>120,000 h
L80 (20k)	>120,000 h
L70 (20k)	>120,000 h
Lumens ¹	46,500
CIE correlated color temperature	5700 K
Color rendering index (CRI)	75 typ, 70 min
LED binning tolerance	7-step MacAdam Ellipse

Footnotes:

1) Incorporates appropriate dirt depreciation factor for life of luminaire.

All components from foundation to poletop are designed to work together in Light-Structure System™ to ensure reliable, trouble-free operation.

Luminaire and Driver – TLC-LED-400

Driver Data

Electrical Data

Rated wattage¹

Per driver	800 W
Per luminaire	400 W
Number of luminaires per driver	2
Starting (inrush) current	<40 A, 256 μ s
Fuse rating	15 A
UL, IEC ambient temperature rating, electrical components enclosure	50°C (122°F)
Ingress protection, electrical components enclosure	IP54
Efficiency	95%
Dimming mode	optional
Range, energy consumption	26 – 100%
Range, light output	30 – 100%
Flicker	<2%
Total harmonic distortion (THD) at full output	<20%

Typical Wiring

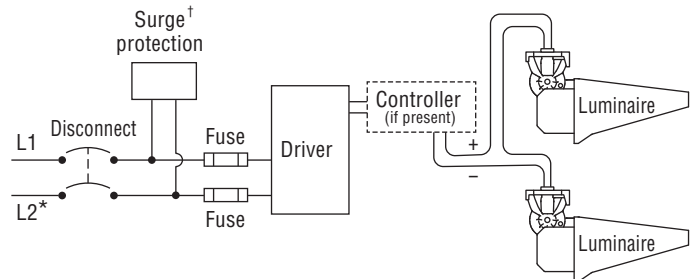

* If L2 is neutral then not switched or fused.
 † Not present if indoor installation.

	200 Vac 50/60 Hz	208 Vac 60 Hz	220 Vac 50/60 Hz	230 Vac 50 Hz	240 Vac 50/60 Hz	277 Vac 60 Hz	347 Vac 60 Hz	380 Vac 50/60 Hz	400 Vac 50 Hz	415 Vac 50 Hz	480 Vac 60 Hz
Max operating current per luminaire ²	2.40 A	2.31 A	2.18 A	2.09 A	2.00 A	1.73 A	1.39 A	1.27 A	1.20 A	1.16 A	1.00 A

Footnotes:

- 1) Rated wattage is the power consumption, including driver efficiency losses, at stabilized operation in 25°C ambient temperature environment.
- 2) Operating current includes allowance for 0.90 minimum power factor, operating temperature, and LED light source manufacturing tolerances.

Notes

1. Use thermal magnetic HID-rated or D-curve circuit breakers.
2. See *Musco Control System Summary* for circuit information.

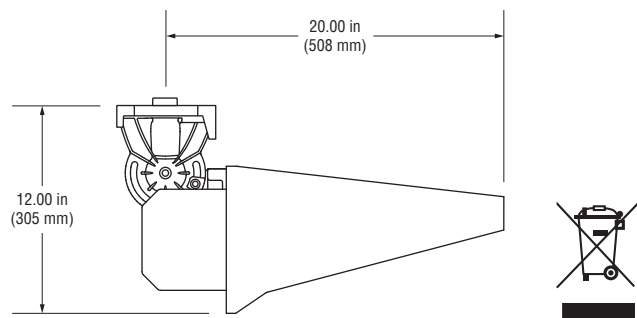
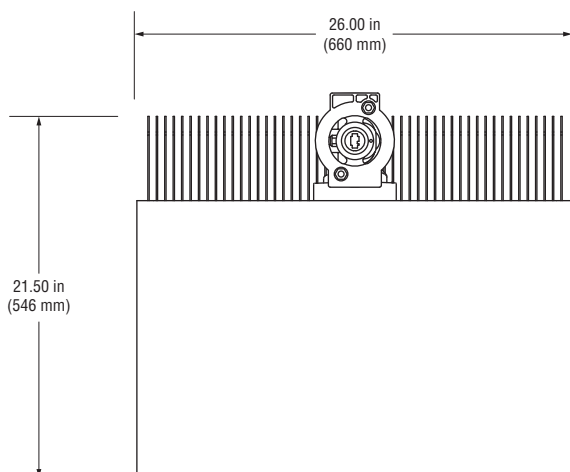

PRELIMINARY FOUNDATION AND POLE ASSEMBLY DRAWING

TABLE 1: POLE ASSEMBLY

POLE ID	POLE HEIGHT ft (m)	# OF LUMINAIRES	ASSEMBLED POLE WEIGHT ³ lb (kg)
P1	30 (9.1)	1	378 (171)
P2	30 (9.1)	1	378 (171)
P3	30 (9.1)	1	378 (171)
P4	30 (9.1)	1	378 (171)
P5	30 (9.1)	1	378 (171)
P6	30 (9.1)	1	378 (171)
P7	30 (9.1)	1	378 (171)
P8	30 (9.1)	1	378 (171)
P9	30 (9.1)	2	443 (201)
P10	30 (9.1)	2	443 (201)
P11	30 (9.1)	2	443 (201)
P12	30 (9.1)	2	443 (201)

TABLE 2: FOUNDATION DETAILS

POLE ID	CONCRETE BASE WEIGHT lb(kg)	BURIAL INFORMATION ^{3,4}		CONCRETE BACKFILL ^{1,2} yd ³ (m ³)	CUT BASE	LIGHTNING GROUND ⁵	
		G in (mm)	H ft (m)			TYPE	SUPPLEMENTAL INSTRUCTION
P1	1100 (499)	30 (762)	8 (2.4)	1.0 (0.7)	NO	INTEGRATED ⁶	N/A
P2	1100 (499)	30 (762)	8 (2.4)	1.0 (0.7)	NO	INTEGRATED ⁶	N/A
P3	1100 (499)	30 (762)	8 (2.4)	1.0 (0.7)	NO	INTEGRATED ⁶	N/A
P4	1100 (499)	30 (762)	8 (2.4)	1.0 (0.7)	NO	INTEGRATED ⁶	N/A
P5	1100 (499)	30 (762)	8 (2.4)	1.0 (0.7)	NO	INTEGRATED ⁶	N/A
P6	1100 (499)	30 (762)	8 (2.4)	1.0 (0.7)	NO	INTEGRATED ⁶	N/A
P7	1100 (499)	30 (762)	8 (2.4)	1.0 (0.7)	NO	INTEGRATED ⁶	N/A
P8	1100 (499)	30 (762)	8 (2.4)	1.0 (0.7)	NO	INTEGRATED ⁶	N/A
P9	1100 (499)	30 (762)	8 (2.4)	1.0 (0.7)	NO	INTEGRATED ⁶	N/A
P10	1100 (499)	30 (762)	8 (2.4)	1.0 (0.7)	NO	INTEGRATED ⁶	N/A
P11	1100 (499)	30 (762)	8 (2.4)	1.0 (0.7)	NO	INTEGRATED ⁶	N/A
P12	1100 (499)	30 (762)	8 (2.4)	1.0 (0.7)	NO	INTEGRATED ⁶	N/A

Pole Assembly Notes:

1. Steel pole should overlap concrete base and be seated tight with 1 1/2 ton come-alongs (contractor provided).
2. Align weldmarks on steel sections before assembling.
3. Assembled pole weight includes steel sections, crossarms, luminaires, and electrical components enclosures. If pole has stamped structural design then use pole weight (listed as vertical force) on stamped structural design document.
4. Section overlap must be pulled together until tight. Overlap measurement should be +/- 6 in (150 mm).
5. This document is not intended for use as an assembly instruction. See *Installation Instructions: Light-Structure System™ Lighting System* for complete assembly procedure.

Foundation Notes:

1. Concrete backfill is calculated to 2 ft (0.6m) below grade (no overage included). Top 2 ft (0.6m) to be class 5 soil compacted to 95% density of surrounding undisturbed soil unless otherwise specified in stamped structural design.
2. Concrete backfill required 3000 lb/in² (20 MPa) minimum.
3. Foundation design per 2011 AS 1170.2, Regions A1-A7 mps, exposure category Cat-2, variation STD.
4. Assumes IBC class 5 soils.
5. Standard bases include integrated lightning protection. If bases are cut, supplemental lightning protection is required. Contact Musco for materials and instruction.
6. Lightning protection is a manufacturer installed concrete encased electrode and connector. Ground connection is made when concrete base is installed and footing is poured. No additional steps required.

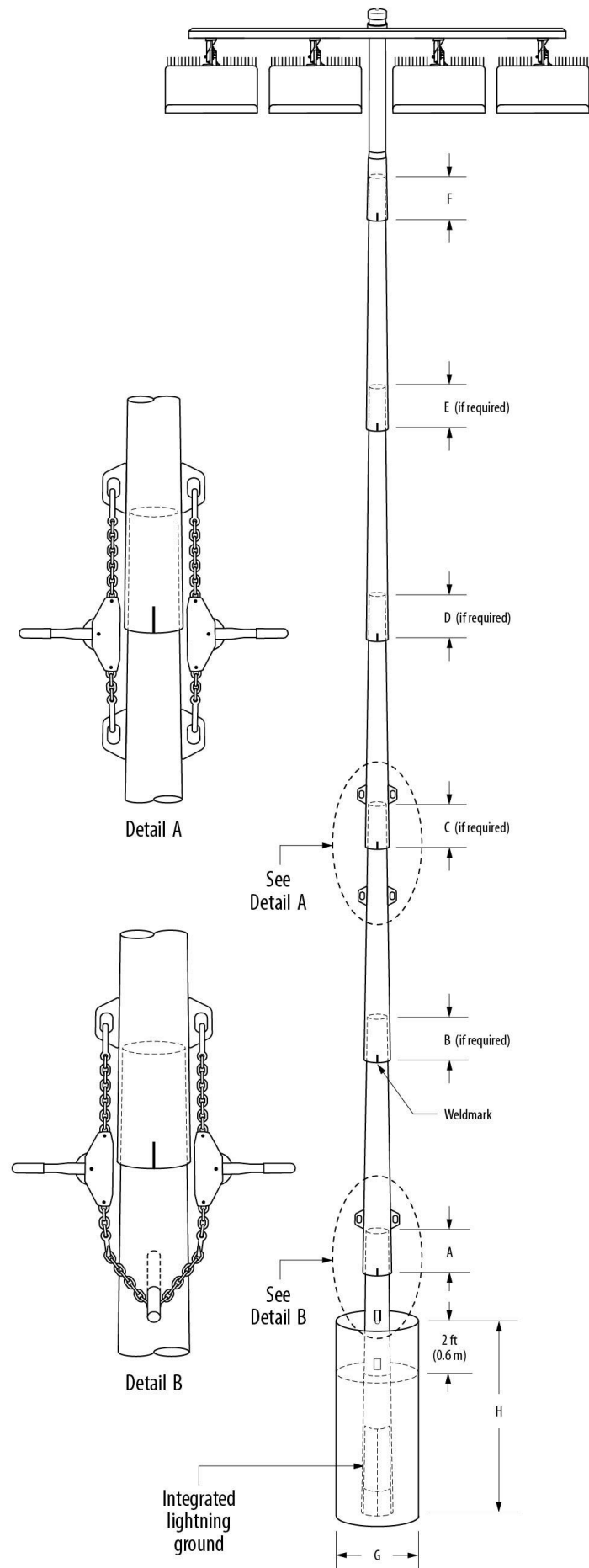

R60-62-00-en04-01_B

Applecross Tennis Club - Applecross, WA, Australia

Date: 09/25/2023

Scale: Not to Scale

Representative: Stuart Thomson

Page: 1 of 1

Project: 230428

PRELIMINARY





Applecross Tennis Club

32 The Strand Applecross

Environmental Noise Assessment

7 December 2023

Report Number: 23061206 - 01a

www.ecoacoustics.com.au

PO Box 502

Byford WA 6122

ACN 135 697 095

Telephone: (08) 9367 1555



Report: 23061206 - 01a

EcoAcoustics Pty Ltd

ATF Ireland Family Trust ABN: 26 450 946 619

Phone: +61 8 9367 1555

KEY PERSONNEL



Rebecca Ireland	Francis Prendergast	Cooper Donovan	Bryn Chatfield
rebecca@ecoacoustics.com.au 0427 388 876	francis@ecoacoustics.com.au 0409 686 492	cooper@ecoacoustics.com.au 0414 4140875	bryn@ecoacoustics.com.au 0498 018 192

Eco Acoustics has prepared this report for the sole use of the Client and for the intended purposes as stated in the agreement between the Client and Eco Acoustics. The report may not be relied upon by any other party without the written permission of Eco Acoustics.

Eco Acoustics has exercised due and customary care in conducting this assessment but has not, save as specifically stated, independently verified any information provided by others. Therefore, Eco Acoustics assumes no liability or loss resulting from errors, omissions or misrepresentations made by others. This report has been prepared at the request of the Client. The use of this report by unauthorised third parties without the written permission of Eco Acoustics shall be at their own risk and Eco Acoustics accept no duty of care to any such third party.

Any recommendations, opinions or findings stated in this report are based on facts as they existed at the time Eco Acoustics performed the work. Any changes in such circumstances and facts upon which this report is based may adversely affect any recommendations, opinions or findings contained within this report.

Document Information

Author:	Rebecca Ireland	Verified:	Francis Prendergast
Position:	Managing Director	Position:	Director
Signature:		Signature	
Date of Issue:	7 December 2023		

Revision History

Revision	Description	Date	Author	Checked



Table of Contents

Executive Summary	i
1 Introduction	1
1.1 Site Locality & Surroundings	1
1.2 Site Layout	1
2 Criteria	5
2.1 Regulation 3(a) – Motor vehicle noise	7
3 Noise Monitoring	9
3.1 Noise Measurement Methodology	9
3.2 Continuous Ambient Noise Monitoring.....	9
4 Onsite Noise Level Measurements	11
4.1 Tennis Court Noise	11
4.2 Residential Measurements	12
5 Noise Impact Assessment	13
5.1 Assessment of Synthetic Grass and Hard Courts General Tennis Activities	13
5.2 Assessment of Short Duration Events	13
6 Conclusion	15
Appendix A	16



Executive Summary

EcoAcoustics Pty Ltd was commissioned by Applecross Tennis Club to conduct an assessment of the changes to the Applecross Tennis Club located at 32 The Strand Applecross. The purpose of this report is to assess the noise emissions from the site in accordance with the prescribed standards contained in the *Environmental Protection (Noise) Regulations 1997*.

The results of the noise measurements show that the Applecross Tennis Club can comply with the assigned noise levels associated with the *Environmental Protection (Noise) Regulations 1997* at nearby residential receivers.



1 Introduction

EcoAcoustics Pty Ltd was commissioned by Applecross Tennis Club to conduct an assessment of the Applecross Tennis Club located at 32 The Strand Applecross. This noise impact assessment report has been completed to provide information relating to the noise impact of the change of ground surface to the tennis courts. The purpose of this report is to assess the noise emissions from the site in accordance with the prescribed standards contained in the *Environmental Protection (Noise) Regulations 1997*.

Appendix A contains a description of some of the terminology used throughout this report.

1.1 Site Locality & Surroundings

The site is located at 32 The Strand Applecross within the City of Melville. The nearest noise sensitive premises located across The Strand, to the south of the site. The site and surroundings are shown in an aerial photo in *Figure 1.1*.



Figure 1.1: Site and Surroundings (Source: Google Earth)

1.2 Site Layout

While the tennis club has been located at this site for many years, the court surfaces have changed. It is understood that Courts 1 to 10 have remained grass courts, while Courts 11 and 12 are synthetic grass courts and Courts 13 and 14 are now hard courts, utilising the Laykold Masters Gel System surface. The layout of the tennis courts is presented on *Figure 1.2*.



Figure 1.2: Tennis Court Site Plan (source: Google Earth)



The Applecross Tennis club site contains existing tennis courts which have been located here since the early 1900's. The general use of the tennis courts has been continuous for the entire duration that the courts have been on the site. The site has recently undergone some upgrades, including the installation of flood lights to allow for use during the evenings until 10pm and the resurfacing of four courts, to future weatherproof the site. Courts 13 and 14, located adjacent to the river and furthest from the neighbouring residents, have been resurfaced with a synthetic rubberized surface, known as Laykold Masters Gel System allowing a cushioned hard court. Courts 11 and 12, located across The Strand from the nearest residential premises, have been resurfaced with synthetic grass, which has similar acoustic properties to natural grass – the previous surface. Currently, the site caters to a social contingent of patrons, along with coaching and development squads. Courts are used daily, with grass courts preferred during the dry months for social games and the upgraded hard and synthetic courts used for coaching and winter months. Two tournaments are held at the site per year, with the Applecross Junior Tournament running for four days over the January School holidays, and the Melville Cup, which is typically by invitation operating on Australia Day between 1pm and 5pm prior to the City of Perth Fireworks in the evening, which is highly visible from the site.

Noise associated with the upgrades to the site include:

- Ball hitting the ground/racquet;
- People talking on court;
- Shoes squeaking on Courts 13 and 14;
- Occasional grunting/groaning from competitors;

It is important to note that the site has existed with courts in these locations for many years, as such, the main changes to the noise landscape are the introduction of different surfaces, thus shoe squeaking and the like. People talking, competitors occasionally grunting and even balls hitting racquets have been present at the site and are not different to previous noises experienced in the vicinity of the tennis club.

The upgrades to the site have coincided with the City of Melville upgrading the local road including the kerbs, paths, road surface and also adding additional roadside car parking. The road improvements provide local street parking access for users of the tennis club, the adjacent parkland and residents or visitors to properties located along The Strand. As this carparking is located within the road reserve, and the upgrades have been conducted by Council, it is considered that any noise impact assessment of the parking would have been completed by the City of Melville. Conducting a noise assessment of this local roadside car parking is considered to be inappropriate as this is outside of the jurisdiction of the Applecross Tennis Club. *Figure 1.3* provides a plan showing the City of Melville road upgrades.



2 Criteria

In Western Australia all Environmental noise is regulated by the *Environmental Protection Act 1986* and the *Environmental Protection (Noise) Regulations 1997*. Noise emissions from the site upgrades are required to satisfy the assigned noise levels specified in Regulations 7, 8 and 9.

The standard stipulated in Regulation 7 of the Environmental Protection (Noise) Regulations 1997 states:

7. (1) Noise emitted from any premises or public place when received at other premises –
- a) Must not cause or significantly contribute to, a level of noise which exceeds the assigned level in respect of noise received at premises of that kind; and
 - b) Must be free of –
 - Tonality;
 - Impulsiveness; and
 - Modulation.

Regulation 9 defines tonality, impulsiveness and modulation. It is regarded that noise is free of these characteristics if:

- a) Tonality, impulsiveness and modulation cannot be equitably removed by means other than decreasing the overall level of noise emission; and
- b) Subsequent to any adjustments as displayed in *Table 2.1* noise emissions remain compliant with the required standards when measured at the point of reception.

Table 2.1: Adjustments for Intrusive Characteristics

Tonality	Modulation	Impulsiveness
+ 5dB	+ 5dB	+ 10dB

The baseline assigned levels (prescribed standards) are specified in Regulation 8 and are shown below in *Table 2.2*.



Table 2.2: Baseline Assigned Noise Levels

Premises Receiving Noise	Time Of Day	Assigned Level (dB)		
		L _{A10}	L _{A1}	L _{Amax}
Noise Sensitive	0700 to 1900 hours Monday to Saturday (Day)	45 + influencing factor	55 + influencing factor	65 + influencing factor
	0900 to 1900 hours Sunday and public holidays (Sunday)	40 + influencing factor	50 + influencing factor	65 + influencing factor
	1900 to 2200 hours all days (Evening)	40 + influencing factor	50 + influencing factor	55 + influencing factor
	2200 hours on any day to 0700 hours Monday to Saturday and 0900 hours Sunday and public holidays (Night)	35 + influencing factor	45 + influencing factor	55 + influencing factor
Commercial	All hours	60	75	80
Industrial	All hours	65	80	90

For the residences located adjacent to the site, an influencing factor of 2 has been determined for those residential premises within 100m of the tennis clubhouse. All other residential premises have an influencing factor of 0. Based on the influencing factors discussed above, the assigned noise levels are shown in *Table 2.3*.



Table 2.4: Assigned Noise Levels

Premises Receiving Noise (Ref Fig 1.1)	Time Of Day	Assigned Level (dB)		
		L _{A10}	L _{A1}	L _{Amax}
29 to 41 The Strand (R3, R4, R5, R6)	0700 to 1900 hours Monday to Saturday (Day)	47	57	67
	0900 to 1900 hours Sunday and public holidays (Sunday)	42	52	67
	1900 to 2200 hours all days (Evening)	42	52	57
	2200 hours on any day to 0700 hours Monday to Saturday and 0900 hours Sunday and public holidays (Night)	37	47	57
43 & 45 The Strand (R1 & R2)	0700 to 1900 hours Monday to Saturday (Day)	45	55	65
	0900 to 1900 hours Sunday and public holidays (Sunday)	40	50	65
	1900 to 2200 hours all days (Evening)	40	50	55
	2200 hours on any day to 0700 hours Monday to Saturday and 0900 hours Sunday and public holidays (Night)	35	45	55

2.1 Regulation 3(a) – Motor vehicle noise

Regulation 3 states:

3. Regulations do not apply to certain noise emissions

(1) Nothing in these regulations applies to the following noise emissions –

(a) noise emissions from the propulsion or braking systems of motor vehicles operating on a road;

Based on discussions with the Department of Environment Regulation noise from cars and trucks associated with the propulsion or braking travelling within a car park are not required to comply with the assigned noise levels as a road is defined as:

“road” means any highway, road or street open to or used by, the public, and includes every carriageway, footway, reservation, median strip and traffic island thereon;

As noted previously and referring to the plan shown in Figure 1.3, the carparking that will be utilised by the tennis club is located within the road reserve, with full public access. This designated road



reserve car parking, along with the adjoining road reserve, has been upgraded by the City of Melville. It has full public access and is not limited to use by the tennis club. In addition, the tennis club has no jurisdiction on the parking within the space, thus, it has not been considered further in this report.



3 Noise Monitoring

3.1 Noise Measurement Methodology

The Regulations specify certain requirements when conducting noise measurements. These requirements are defined in Regulations 19, 20, 22 and 23 and Schedule 4. Site noise measurements have satisfied these requirements, with the following detailed:

- Handheld noise measurements were completed on the site using a Type 1 Sound Level Meter, Rion NL52 (s/n: 00297846).
- Continuous noise logging was completed near the site using a Type 2 BSWA noise logger (s/n: 560520)
- Both sound level meters hold current laboratory certificate of calibration, available upon request;
- They were calibrated before and after the measurements and was found to be within 0.1dB of the reference signal;
- Both meters record slow and fast time weighted sound levels, allowing relevant data to be collected;
- The microphones were fitted with a standard wind screen;
- During the measurements, the microphone was at least 1.3 metres above the ground level and at least 3 metres from reflecting facades (other than the ground plane); as such no adjustments have been applied for reflected noise.

Hand held noise measurements were taken at the tennis club on 21st July 2023, while noise logging was completed over a 4-day period commencing Friday 21st July 2023. Average meteorological conditions at the time, recorded at the Bureau of Meteorology's Perth site, were:

- Temperature: 4.4°C to 21.6°C
- Relative Humidity: 31 - 64%
- Note periods of rainfall have been disregarded in the measurement period

3.2 Continuous Ambient Noise Monitoring

The results of the noise logging are summarised in *Table 3.1*.



Table 3.1: Measured Average Noise Levels

Time of Day	Average Noise Level, dB (A)			
	L_{Aeq}	L_{A1}	L_{A10}	L_{A90}
Day (7am to 7pm)	50	57	51	40
Evening (7pm to 10pm)	49	51	44	37
Sunday (9am to 10pm)	51	57	53	46
Night (10pm to 7am)	44	46	42	39



4 Onsite Noise Level Measurements

4.1 Tennis Court Noise

In addition to the noise logging, individual measurements were taken of a number of tennis matches on the synthetic grass courts, namely Courts 11 and 12, along with the hard courts, namely Courts 13 and 14. The average results of the individual measurements are presented in Table 4.1.

Table 4.1: Handheld Noise Level Measurements from Tennis Courts

Noise source	Distance (to nearest point), m	Appropriate parameter	Measured Noise Levels, dB (A)
Shoe Squeaks	1.5m	L _{Amax}	78
Athlete groaning	3m	L _{Amax}	68
Racquet hitting ball	3m	L _{A1}	64
General tennis coaching	3m	L _{A10}	55

Measurements were also taken using an unattended noise logger within close proximity to the courts over a weekend period to determine the different usage may have on the overall noise levels. Table 4.2 presents the noise data measured during the court usage from Friday until Sunday afternoon within close proximity to the courts. The location was approximately 6m from the fence at Courts 11 and 12, and 45m to the closest fence at Courts 13 and 14.

Table 4.2: Measured Average Noise Levels during Tennis Club Operations on 21st to 23rd July 2023

Day	Recorded usage – including courts	Time of Day	Average Noise Level, dB (A)			
			L _{Amax}	L _{A1}	L _{A10}	L _{A90}
Friday	Social tennis Courts 11, 12, 13 & 14	2:30pm to 5:30pm	67	60	54	38
Saturday	Junior and senior coaching Courts 11, 12, 13 & 14	7am to 12pm	66	58	53	46
Saturday afternoon	Social tennis Courts 11, 12, 13 & 14	1:30pm to 5pm	69	60	55	45
Sunday	Social tennis – Courts 11, 12, 13 & 14	3pm to 5pm	64	57	52	46

The results in Table 4.2 show that there is very little variation in the noise emitted by the site under each of the different types of everyday activities.



4.2 Residential Measurements

Measurements were taken at a number of locations representative of the nearest noise sensitive receivers, in an attempt to measure the impact of the newly resurfaced courts onto the residential premises. Note that the measurement location was along the road frontage, thus approximately 10 – 15m from the houses. Site activities during the noise level measurements included athletes on Courts 11, 12, 13 and 14 under coaching and also socially competing. The measurement results are shown in *Table 4.2*.

Table 4.2: Measured Noise Levels at Residential Premises

Location	Duration	Noise Sources	Measured Noise Levels, dB (A)		
			L _{Amax}	L _{A1}	L _{A10}
39A The Strand (R4)	15 minutes	Noise from tennis not discernible above background – L _{Amax} from vehicles and birds	67	61	50
41 The Strand (R3)	15 minutes	Noise from tennis generally not discernible above background – L _{Amax} from vehicles and birds	66	63	48
23 The Strand (background only tennis club inaudible)	15 minutes	Vehicles, birds, general noise from residential properties	66	58	54



5 Noise Impact Assessment

5.1 Assessment of Synthetic Grass and Hard Courts General Tennis Activities

Table 5.1 presents the predicted L_{A10} noise levels from the general tennis activities, including matches, rallies and activities on the synthetic grass and hard courts based on the measurements taken within the tennis club surrounds. Calculations have been based on the actual measurements associated with the site and compares this to the Regulations for the daytime, Sunday and evening periods.

Table 5.1: Predicted L_{A10} Noise from Tennis Club

Location (ref Figure 1.1)	Predicted Noise Level, L_{A10} , dB(A)	Assigned Noise Level, Day dB(A)	Complies with Assigned Noise Level, Day	Assigned Noise Level, Evening/Sunday dB(A)	Complies with Assigned Noise Level, Evening/Sunday
R1 45 The Strand	38	45	Yes	40	Yes
R2 43 The Strand	35	45	Yes	40	Yes
R3 41 The Strand	34	47	Yes	42	Yes
R4 39A The Strand	34	47	Yes	42	Yes
R5 39 The Strand	33	47	Yes	42	Yes
R6 37 The Strand	31	47	Yes	42	Yes

The predicted noise levels from general noise associated with the tennis courts complies with the daytime, evening and Sunday assigned noise levels.

5.2 Assessment of Short Duration Events

Table 5.2 presents the predicted noise levels associated with short duration events such as racquets hitting ball, ball bouncing on hard surface and shoe squeaks compares these to the Regulations. Onsite measurements and attempts to determine the presence or absence of intrusive characteristics at the neighbouring residential locations were made, and the results showed that tonality was not measurable from shoe squeaks on Courts 13 and 14. Similarly, the determination of impulsiveness requires the difference between L_{Apeak} and $L_{A\ slow\ max}$ to be 15dB when determined for a single representative event. Measurements of short duration events were taken at a location representative of the nearby residents. At this distance, the difference between L_{Apeak} and $L_{A\ slow\ max}$ was less than 15 dB for individual short duration events.



Table 5.2: Noise from Short Duration Events

Location (ref Figure 1.1)	Predicted Noise Level, L _{Amax} , dB(A)	Assigned Noise Level, L _{Amax} Day & Sunday dB(A)	Complies with Assigned Noise Level, Day & Sunday	Assigned Noise Level, L _{Amax} Evening dB(A)	Assigned Noise Level, L _{Amax} Evening dB(A)
Shoe Squeaks					
R1 45 The Strand	43	65	Yes	55	Yes
R2 43 The Strand	44	65	Yes	55	Yes
R3 41 The Strand	44	67	Yes	57	Yes
R4 39A The Strand	45	67	Yes	57	Yes
R5 39 The Strand	45	67	Yes	57	Yes
R6 37 The Strand	45	67	Yes	57	Yes
Racquet Hitting Ball/Ball Bouncing on Surface					
R1 45 The Strand	51	65	Yes	55	Yes
R2 43 The Strand	52	65	Yes	55	Yes
R3 41 The Strand	50	67	Yes	57	Yes
R4 39A The Strand	51	67	Yes	57	Yes
R5 39 The Strand	50	67	Yes	57	Yes
R6 37 The Strand	49	67	Yes	57	Yes

The results presented in Table 5.2 show that the predicted noise levels based on the measured noise levels complies with the assigned noise levels during the daytime evening and Sunday periods.



6 Conclusion

The results of the noise predictions show that the proposed changes to the Tennis Court site can comply with the assigned noise levels associated with the *Environmental Protection (Noise) Regulations 1997* at nearby residential receivers.



Appendix A

Terminology

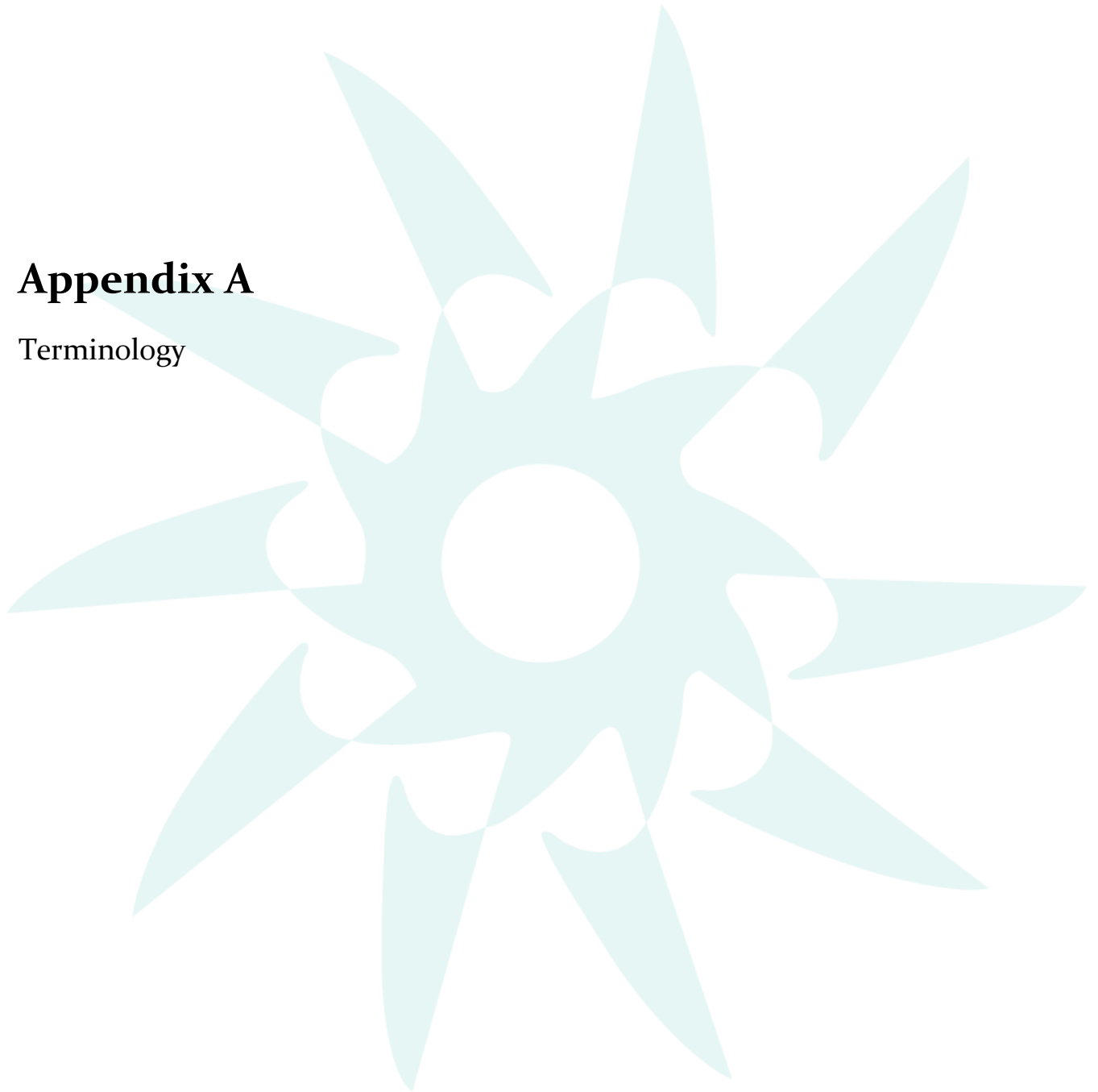



Terminology

Ambient Noise

Ambient noise refers to the level of noise from all sources, including background noise as well as the source of interest.

A-Weighting

An A-weighted noise level is a noise level that has been filtered as to represent the way in which the human ear distinguishes sound. This weighting indicates the human ear is more sensitive to higher frequencies than lower frequencies. The A-weighted sound level is described as L_A dB.

Background Noise

Background noise is the noise level from sources other than the source of interest. Background may originate from such things as traffic noise, wind induced noise, industrial noise etc.

Decibel (dB)

The decibel is the unit that characterises the sound power levels and sound pressure of a noise source. It is a logarithmic scale with regard to the threshold of hearing.

Impulsive Noise

An impulsive noise source is a short-term impact noise which may originate from such things as banging, clunking or explosive sound.

Influencing factor

$$= 1/10 (\% \text{ Type } A_{100} + \% \text{ Type } A_{450}) + 1/20 (\% \text{ Type } B_{100} + \% \text{ Type } B_{450})$$

Where:

% Type A_{100} = The percentage of industrial land within a 100m radius of the premises receiving noise

% Type A_{450} = The percentage of industrial land within a 450m radius of the premises receiving noise

% Type B_{100} = The percentage of commercial land within a 100m radius of the premises receiving noise

% Type B_{450} = The percentage of commercial land within a 450m radius of the premises receiving noise

+ Traffic factor (maximum 6 dB)

= 2 for each secondary road within 100m

= 2 for each major road within 450m

= 6 for each major road within 450m



L_{A1}

An L_{A1} level is the A-weighted noise level which is overreached for one percent of a measurement period. It represents the average of the maximum noise levels measured.

L_{A1} assigned level

An assigned L_{A1} level which is not to be exceeded for more than 1% of a delegated assessment period.

L_{A10} assigned level

An assigned L_{A10} level which is not to be exceeded for more than 10% of a delegated assessment period.

L_{A10}

An L_{A10} level is the A-weighted noise level which is exceeded for 10 percent of the measurement period and is considered to represent the “intrusive” noise level.

L_{A90}

An L_{A90} level is the A-weighted noise level which is overreached for 90 percent of the measurement period. It represents the “background” noise level.

L_{Aeq}

L_{Aeq} refers to the comparable steady state of an A-weighted sound which, over a specified time period, contains the same acoustic energy as the time-varying level during the specified time period. It represents the “average” noise level.

L_{AFast}

The noise level in decibels, obtained using the A frequency weighting and the F time weighting as specified in AS1259.1-1990. L_{AFast} is used when examining the presence of modulation.

L_{Amax}

The L_{Amax} level is the maximum A-weighted noise level throughout a specified measurement.

L_{Amax} assigned level

The L_{Amax} assigned level describes a level which is not to be exceeded at any time.

L_{APeak}

The L_{APeak} level is the maximum reading (measured in decibels) during a measurement period, using the A frequency weighting and P time weighting AS1259.1-1990.



L_{ASlow}

A L_{ASlow} level is the noise level (measured in decibels) obtained using the A frequency weighting and S time weighting as specified in AS1259.1-1990

Major Road

A Major road has an estimated average daily traffic count of more than 15,000 vehicles.

Maximum Design Sound Level

Maximum Design Sound Level is the level of noise beyond hearing range of most people occupying the space start, become dissatisfied with the level of noise.

Modulating Noise

A modulating source is an audible, cyclic and regular source. It is present for at least 10% of a measurement period. The quantitative definition of tonality is:

a fluctuation in the discharge of noise which;

- a) is more than 3 dB $L_{A Fast}$ or is more than 3 dB $L_{A Fast}$ in any one-third octave band;
- b) is present for at least 10% of the representative

One-Third-Octave Band

One-Third-Octave-Band are frequencies that span one-third of an octave which have a centre frequency between 25 Hz and 20 000 Hz inclusive.

Representative Assessment Period

Representative Assessment Period describes a period of time not less than 15 minutes, and not surpassing four hours. It is determined by an inspector or authorised person to be suitable for the assessment of noise emissions.

Reverberation Time

Reverberation time refers to an enclosure for a sound of a specified frequency or frequency band as well as the time that would be necessary for the reverberantly decaying sound pressure level in the enclosure to decrease by 60 decibels.

RMS

The root mean square level is used to represent the average level of a wave form such as vibration.

Satisfactory Design Sound Level

Satisfactory Design Sound Level refers to the level of noise that has been found to be acceptable for the environment in question, which is also to be non-intrusive.



Secondary / Minor Road

A Secondary / Minor road has an estimated average daily traffic count of between 6,000 and 15,000 vehicles.

Sound Pressure Level (L_p)

Sound Pressure Level refers to a noise source which is dependent upon surroundings, and is influenced by meteorological conditions, topography, ground absorption; distance etc. Sound Pressure Level is what the human ear actually hears. Noise modelling predicts the sound pressure level from the sound power levels whilst taking into account the effect of relevant factors (meteorological conditions, topography, ground absorption; distance etc).

Sound Power Level (L_w)

A sound power level of a noise source cannot be directly measured using a sound level meter. It is calculated based on measured sound pressure levels at recognised distances. Noise modelling includes source sound power levels as part of the input data.

Specific Noise

Specific Noise relates to the component of the ambient noise of interest. It can be specified as the noise of interest or the noise of concern.

Tonal Noise

A tonal noise source can be designated as a source that has a specific noise emission over one or several frequencies, such as droning. The quantitative definition of tonality is:

the presence in the noise emission of tonal characteristics where the difference between —

- a) the A-weighted sound pressure level in any one-third octave band; and
- b) the arithmetic average of the A-weighted sound pressure levels in the 2 adjacent one-third octave bands, is greater than 3 dB when the sound pressure levels are determined as $L_{Aeq,T}$ levels where the time period T is greater than 10% of the representative assessment period, or greater than 8 dB at any time when the sound pressure levels are determined as $L_{A Slow}$ levels.



Chart of Noise Level Descriptors

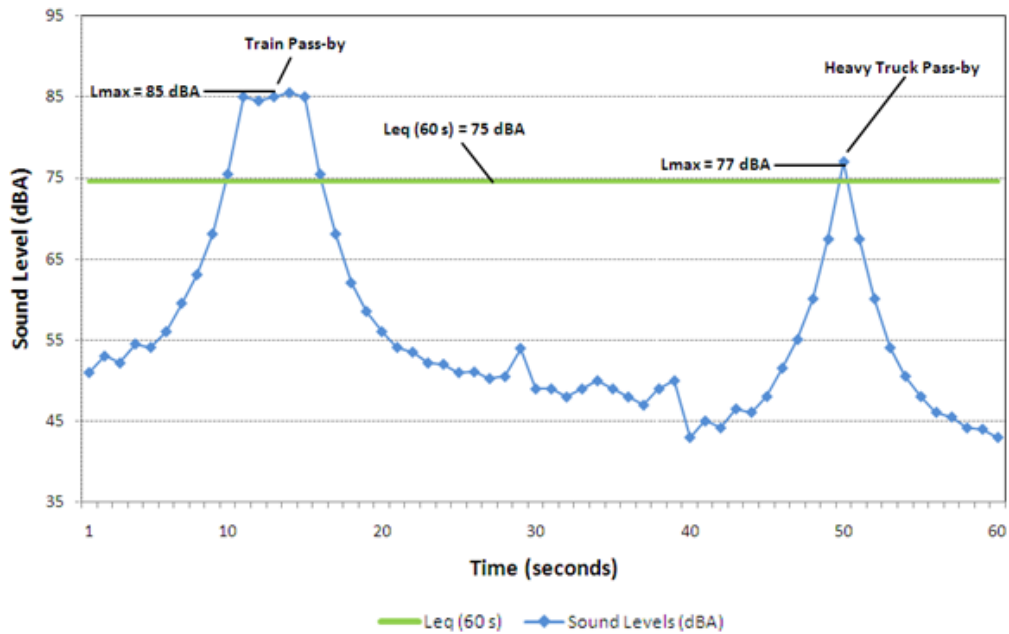

Typical Noise Levels

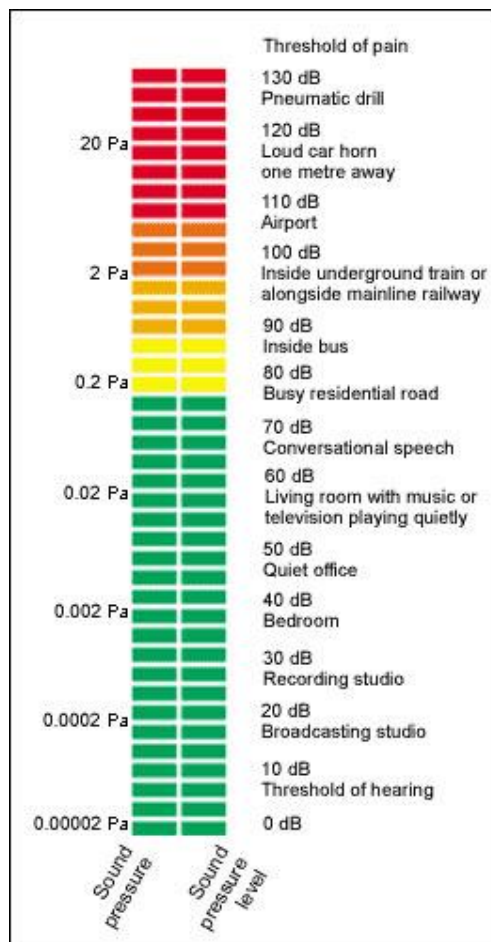

To: Applecross Tennis Club

From: Rebecca Ireland

Attention: Paul Logothetis

Date: 21 March 2024

Email: [REDACTED]

Pages: 2

Reference: 23061206-02

Re: Applecross Tennis Club, Response to DWER Request for Additional Information

Dear Paul,

We refer to the email from Department of Water and Environment Regulation (DWER) and the attached review of our noise impact assessment completed for the Applecross Tennis Club (our ref: 23061206-01 dated 7th December 2023). This letter provides a response to the queries contained within the review.

Additional Noise Monitoring

To provide DWER with additional information for the review process, EcoAcoustics has completed additional noise monitoring and noise logging at the site and nearby residential premises. The results are presented below.

Noise Logging

Noise logging was conducted during the evening to determine the noise levels at the nearby residential premises. The resultant noise levels are summarised in Table 1.

Table 1: Summary of Measured Noise Levels

Location	Average Noise Level between 7pm and 10pm, dB(A)		
	L_{A01}	L_{A10}	L_{A90}
39The Strand	51	48	39



Monitoring of Noise Sources

In addition to the noise logging, handheld measurements were taken at 2 locations simultaneously to measure the actual noise from the four courts. Measurements were taken at close proximity to men playing on the courts, while additional handheld measurements were taken at the boundary of the closest residential premises to the courts in use. Both measurement locations were manned by staff, with the staff noting down actual audible sounds during the testing along with resultant noise levels from the sources, including shoe squeaks, racquets hitting balls and coaching.

Measurements were taken over about a 60-minute period, to allow for the removal of extraneous noise as a result of traffic, birds, dogs, people in the community taking and walking dogs etc. measurements were taken with sound level meters, (Type 2 Norsonic Nor 131 and Type 1 Rion NL52) both calibrated before and after the measurements and found to be within 0.2 of the reference signal. Measurements were taken in free field situations, at least 2m from any reflecting facades (other than the ground plane).

The measured noise levels are presented in Table 2 & 3.

Table 2: Noise Measurements from Shoes Squeaking

Noise Source	Applecross Tennis Club (approximately 2m – 3m from source) dB(A)	Adjacent to Boundary of 41 The Strand, approximately 53m to source) (as noise occurred without extraneous noise), dB(A)	With a penalty adjustment of +10dB(A)
Shoe Squeaking Courts 13 & 14 only	66	44	54
	68	46	56
	76	47	57
	74	45	55

Table 3: Noise Measurements from Racquets Hitting Balls

Noise Source	Applecross Tennis Club (approximately 5m – 15m from source) dB(A)	Adjacent to Boundary of 43 The Strand, approximately 33m to source) (as noise occurred measured without extraneous noise), dB(A)
Racquet Hitting Balls Courts 11 & 12 – worst case location	52	40
	50	38
	53	40
	55	42



Comparing these results to the measured ambient noise during the evening, it can be seen that the predicted noise levels associated with the racquet hitting balls on the court are well below the existing L_{A10} levels, and similar to the L_{A90} background levels, which would result in the sound not discernible above the ambient noise. Thus, the addition of a penalty adjustment is not applicable.

Similarly, the shoe squeak noise levels are similar to the measured evening noise levels, however, to provide a worst case scenario, based on the worst case measurements, Table 1 shows the inclusion of a penalty adjustment of +10dB for impulsiveness. This shows compliance with the assigned noise levels at the closest boundary. It follows that the house is located further from the boundary, thus noise levels will be lower.

It is important to note that these measurements were taken during men's tennis matches within the Courts. During normal sessions in the afternoons and evenings, children, teens and adults use the sites, thus it is likely that noise levels associated with children and teens playing will be lower than the measured men's match.

Similarly, the shoe squeaks were measured from a player with synthetic court shoes on – chosen for the loudest noise measurements. The other player had hard court shoes and his shoes did not squeak at all. In general, from discussions with the Tennis Club, those players using the hard courts would generally use hard court shoes as these are less likely to damage the surface of the courts. It is important to note that during the site visit, shoe squeaking on the hard courts was observed only twice during normal use of the courts. The measurements from shoes squeaking based on an exaggerated simulation.

1/3 Octave Band Measurements

In addition to the overall measurements, 1/3 octave band spectra data was also measured during the close-up measurements of the shoe squeaks and racquets hitting the balls. The results of the maximum measured noise levels are presented in Chart 1.

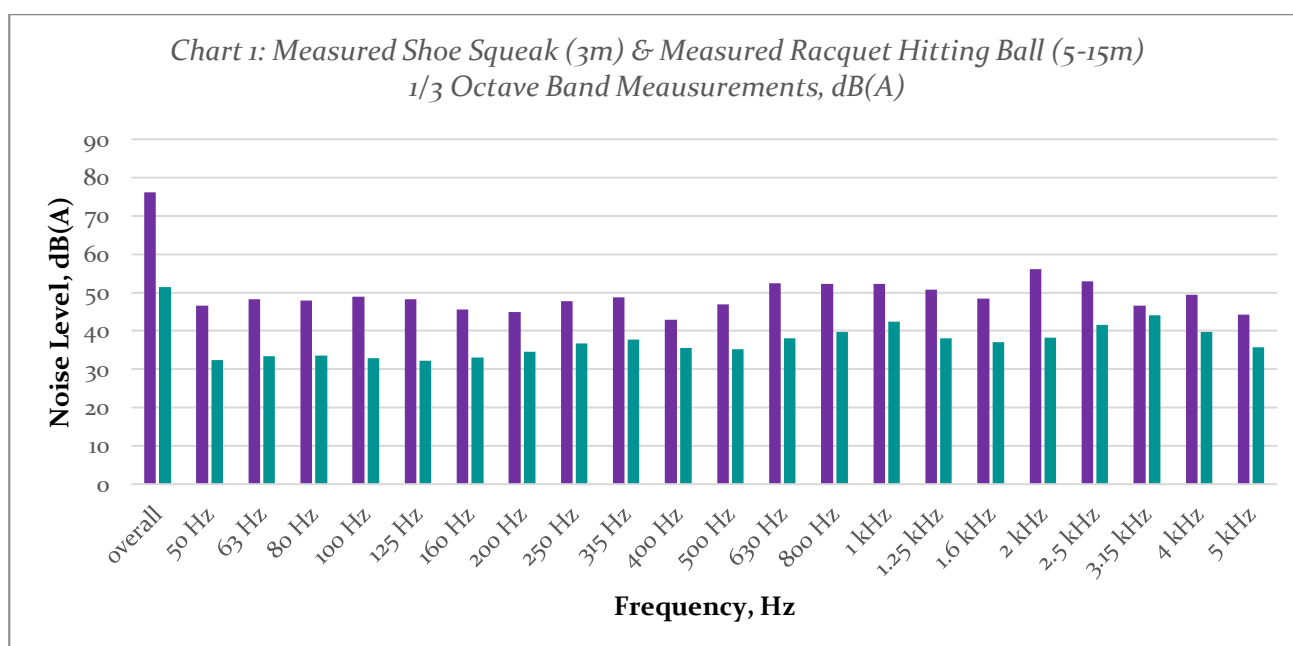



We trust the above is acceptable. Should you require further information please do not hesitate to contact us.

Regards,

Rebecca Ireland
Managing Director